



Faculty of Economic Sciences, Communication and IT
Psychology

Sven-Åke Bood

Bending and Mending the Neurosignature

Frameworks of influence by flotation-REST
(Restricted Environmental Stimulation Technique)
upon well-being in patients with stress related ailments

DISSERTATION
Karlstad University Studies
2007:25

Sven-Åke Bood

Bending and Mending the Neurosignature

Frameworks of influence by flotation-REST
(Restricted Environmental Stimulation Technique)
upon well-being in patients with stress related ailments

Sven-Åke Bood. *Bending and Mending the Neurosignature - Frameworks of influence by flotation-REST (Restricted Environmental Stimulation Technique) upon well-being in patients with stress related ailments*

DISSERTATION

Karlstad University Studies 2007:25

ISSN 1403-8099

ISBN 978-91-7063-128-3

© The author

Distribution:

Faculty of Economic Sciences, Communication and IT

Psychology

SE-651 87 Karlstad

SWEDEN

forlag@kau.se

+46 54-700 10 00

www.kau.se

Printed at: Universitetstryckeriet, Karlstad 2007

To Maja-Lisa Bood, Ingeborg Bood, Matthias Sjöstedt, Lisa Bood, Kajsa Bood, and Emil Bood and to the memory of Tore Bood.

Doctorial dissertation: Bending and Mending the Neurosignature. Frameworks of influence by flotation-REST (Restricted Environmental Stimulation Technique) upon well-being in patients with stress related ailments

Sven-Åke Bood, Department of Psychology and Law, Karlstad University, Sweden.

Abstract.

The overarching purpose of the current thesis was to assess the long term effects of a treatment program involving flotation-REST for the experience of pain, from the point of view of variables connected with Melzack's neuromatrix theory, and to examine the extent of a potential attention-placebo effect in connection with flotation-REST.

The first study (**Paper I**) aimed to investigate long-term effects of flotation-REST four months after treatment. Seventy patients participated, diagnosed as having stress-related pain. Participants were randomly assigned to either a control group or a flotation-REST group and participated in a total of twelve flotation REST or control sessions. Results indicated that pain areas, stress, anxiety and depression decreased, while sleep quality, optimism, and prolactin increased. Positive effects generally maintained four months after treatment. The second (**Paper II**) examined the potential effects of attention-placebo. Thirty-two patients who were diagnosed as having stress-related muscular pain were treated for a period of six weeks. Half of the patients were also given attention for a period of 12 weeks, while the remainder received attention for 6 weeks. Participants in both groups exhibited lowered blood pressure, reduced pain, anxiety, depression, stress, and negative affectivity, as well as increased optimism, energy, and positive affectivity. The third (**Paper III**) investigated whether or not 33 flotation sessions were more effective for stress related ailments as compared to 12 sessions. Participants were 37 patients with stress related ailments. Analyzes for subjective pain and psychological variables typically indicated that 12 sessions were enough to get considerably improvements and no further improvements were noticed after 33 sessions. Finally, the fourth study (**Paper IV**) aimed to examine whether and how the combination of therapy and flotation tank could be used to treat patients with severe stress problems. Two women on long-term sick-leave participated in the study, which was carried out over a period of one year. Four overarching themes were generated: the therapeutic work model, transformation of feelings, self-insight and meaning. These together constituted a "therapeutic circle" which after a while transformed in to a "therapeutic spiral" of increased meaning and enhanced wellbeing.

It was therefore concluded that flotation tank therapy is an effective method for the treatment of stress-related pain.

Key words: Attention-placebo, Burn-out, Depression, Flotation-REST, Pain, Prolactin, Relaxation response, Stress, Therapy.

The thesis is based on the following four research papers, which will be referred to in the text by their Roman numerals:

- I** Bood, S. Å., Sundequist, U., Norlander, T., Nordström, L., Nordenström, K., Kjellgren, A., Nordström, G. &. (2006). Eliciting the relaxation response with help of flotation-REST (Restricted Environmental Stimulation Technique) in patients with stress related ailments. *International Journal of Stress Management*, 13, 154-175.

- II** Bood, S. Å., Sundequist, U., Kjellgren, A., Nordström, G. & Norlander, T. (2005). Effects of flotation-REST (Restricted Environmental Stimulation Technique) on stress related muscle pain: What makes the difference in therapy, attention-placebo, or the relaxation response? *Pain Research and Management*. 10, 201-209.

- III** Bood, S. Å., Sundequist, U., Kjellgren, A., Nordström, G. & Norlander, T. (2007). Effects of Flotation REST (Restricted Environmental Stimulation Technique) on Stress Related Muscle Pain: Are 33 flotation sessions more effective as compared to 12 sessions? *Social Behavior and Personality*, 35, 143-156.

- IV** Åsenlöf, K., Olsson, S., Bood, S. Å., & Norlander, T. (in press). Case studies on fibromyalgia and burn-out depression using psychotherapy in combination with flotation-REST: Personality development and increased well-being. *Imagination, Cognition and Personality*.

Reprints were made with kind permission from the publishers.

Acknowledgements

The Supervisors. First, I wish to express my deep gratitude to my examiner and supervisor Professor Torsten Norlander, Department of Psychology and Law, for introducing me to the fields of experimental and clinical psychology and for being such a patient, encouraging and supportive guide in science throughout all these years. Also, I would like to thank the assistant supervisor Professor Gun Nordström, Department of Health and Care, for her good advice and for her helpful support and encouragement.

The Colleagues. Further, I would like to thank my colleagues at the Karlstad University and Human performance, who have given me important support and many interesting discussions around crucial topics of modern psychology that had been inspiring.

The Participants. I would like to thank all the participants in the four studies, without whom not much would have been achieved.

The Supporters. Thanks to the Department managers at the Central Hospital, Karlstad, Inger Grönberg and Anders Karlsson for their enthusiasm and interest. I am indebted to Professor Ann Frodi for making valuable comments on the manuscript. Thanks to Professor Rolf Ekman and Professor Matti Bergström for many valuable ideas. I also want to thank all of my fellow doctoral candidates at the department of Psychology and a thankful thought goes to the secretary of the department, Inger Jonsson, for her constant support and patience with a sometimes confused doctoral candidate.

Finally, goes my acknowledgement to my wife, Maja-Lisa, who continuously has supported me with love and enthusiasm

Contents

1. INTRODUCTION	5
1.1 Background.....	5
1.1.1 The growing problems of stress and stress-related pain in the Western World	5
1.1.2 The stress response	7
1.1.3 The relaxation response	9
1.1.4 Problems with the elicitation of the RR	11
1.1.5 Flotation-REST	12
1.1.6 The purpose of the current thesis	14
1.2 Theoretical perspectives	14
1.2.1 Melzack's perspective	14
1.2.2 The perspective of Bergström.....	20
1.2.3 The primary and secondary processes	21
2. THE PRESENT INVESTIGATION.....	25
2.1 Introduction.....	25
2.2 Paper I. Flotation-REST with follow-up	26
2.2.1 Aim	26
2.2.2 Design.....	26
2.2.3 Instruments.....	26
2.2.4 Procedure.....	29
2.2.5 Statistics.....	31
2.2.6 Results	31
2.3 Paper II. Flotation with normal or high attention.	32
2.3.1 Aim	32
2.3.2 Design.....	32
2.3.3 Instruments.....	32
2.3.4 Procedure.....	32
2.3.5 Statistics.....	33
2.3.6 Results	34
2.4 Paper III. Flotation with 12 or 33 sessions.	34
2.4.1 Aim	34
2.4.2 Design.....	34
2.4.3 Instruments.....	35
2.4.4 Procedure.....	35
2.4.5 Statistics.....	36
2.4.6 Results	37

2.5 Paper IV. Flotation combined with therapy.....	37
2.5.1 Aim	37
2.5.2 Design.....	37
2.5.3 Procedure.....	38
2.5.4 Processing the data.....	38
2.5.4 Results	39
3. GENERAL DISCUSSION	41
3.1 Introduction.....	41
3.2 How do the results pertain to Melzack’s perspective?.....	41
3.2.1 Non-linear thinking about pain perception	41
3.2.2 Pain measured by the Pain Area Inventory.....	42
3.2.3 Stress and Energy measured by the Stress and Energy Test.....	42
3.2.4 Anxiety and Depression measured by the Hospital Anxiety Depression Scale	43
3.2.5 Optimism measured by the Life Orientation Test	44
3.2.6 Positive and Negative Affectivity measured by the PANAS	44
3.2.7 Quality of Sleep measured by a VAS-scale	44
3.2.8 Blood pressure measured by a sphygmomanometer.....	45
3.2.9 Cortisol and prolactin measured by blood assays	45
3.3 Do non burn-out and burn-out patients have different neurosignatures? .	46
3.4 Why does flotation-REST affect the neurosignature?.....	47
3.4.1 Relaxation is an appropriate therapeutic instrument.....	47
3.4.2 Eliciting the relaxation response in highly stressed people.....	47
3.4.3 Creativity	48
3.4.4 Meaning.....	49
3.4.5 Relative weightlessness	51
3.5 Can the mending of the neurosignature be illustrated?.....	52
3.5.1 Introduction	52
3.5.2 Cognitive strategies	52
3.5.3 Feelings.....	52
3.5.4 Self-Insight/Self Esteem/Self Confidence/Self Image	53
3.5.5 Inner Strength and Courage	54
3.5.6 Presence, Concentration and Focus.....	54
3.5.7 Fear	54
3.5.8 Anger and Frustration	55
3.5.9 Aches and Pains.....	55
3.5.10 Benefits from Illness.....	56
3.5.11 Floating	56
3.5.12 Spirituality and the Superego.....	57

3.5.13 Conversation-Floating-Painting.....	57
3.6 Are there differences between women and men?.....	58
4. CONCLUSIONS	61
5. REFERENCES	63
-APPENDIX-.....	79

1. INTRODUCTION

1.1 Background

1.1.1 The growing problems of stress and stress-related pain in the Western World

During the last two centuries the development of technology has taken place at a furious speed with increasing demands on the individual and the work environment. People have been exposed to a society filled with increasing amounts of information and demands resulting in more and more stress-related strains both at work and outside (Levi, 2002), a fact that implies costs to society at a minimum of 3-4 % of the Gross National Product (Ekman & Arnetz, 2002). Stress-related poor health has also entered into younger ages, and there is a risk that stress in school may negatively affect children's emotional and intellectual development (Ekman & Arnetz, 2002). At the same time, stress-related ill health has increased dramatically in the industrial setting, in the white collar and blue collar domains, in the medical setting, and in the public health sector as well as in telecommunications, information technology, and in communication and the media (Ekman & Arnetz, 2002). The result of advances in information technology is a more computerized work situation and reduced physical activity (Fletcher, 1983), and a greater flow of information leading to experiences of stress, mental overstimulation, mental exertion, a lowered mood, a general sense of powerlessness, muscle tension, and the development of different kinds of stress-related pain (Brattberg, Parker & Thorslund, 1996; Johannisson, 2002; Mobily, Herr, Clark & Wallace, 1994; Norton, Asmundson, Norton & Craig, 1999; Sjöström, 2002). More women than men suffer from auto-immune disorders such as chronic pain. Among the 5 % of the elderly population with autoimmune disorders, 2 out of 3 are women (Berkly, 1997). Gender-related hormonal changes, which appear with increasing age, are of special importance. Estrogen levels increase resulting in a release of peripheral cytochines, e.g. gamma interferons, which in turn produce an increase in cortisol (Melzack, 2001). Most likely, this fact can explain why a greater percentage of women suffer from different types of chronic pain such as painful autoimmune disorders, multiple sclerosis, disorders of the skin with repercussions on the internal organs (Melzack, 2001).

In the year 2000, The Institute of Working Life (Arbetslivsinstitutet) in Sweden conducted a study of burn-out depression. No unified definition exists of this particular state, although there is some general consensus that the definition includes the following symptoms: fatigue, reduced

energy, loss of self esteem, problems with the organization of daily life, problems with memory and the processing of new information, sleep disturbances not relieved through rest, and feelings of low-spiritedness (Bood, Sundequist, Kjellgren, Nordström & Norlander, 2007; Ekstedt & Fagerberg, 2005). The above mentioned study included 4 800 individuals aged 18-64, who were not employed. The results indicated that people who were either unemployed or students, suffered as much from burn-out depression as those who were gainfully employed (Arbetslivsinstitutet, 2006).

Research has also shown that monotonous, cognitive strain, characterizing several new, tightly controlled IT jobs, often leads to mental fatigue (Arbetslivsinstitutet, 2006). The total workload for men has increased by 12 hours per week, between 1994 and 2002, from 60 to 73.5 hours and for women from 73 to 85 hours per week (Prevent, 2006). The increase is based on more unpaid work where women have increased from 29.9 to 41.3 hours per week (Prevent, 2006). Prolonged strain is often associated with a poorer recovery and a significant sense of stress. Poorer recovery is often connected with the consequences seen in the symptomatology of individuals with burn-out. Burn-out depression is regarded as the last stage of stress (Maslach, Schaufeli & Leiter, 2001; Sjukvårdsrådgivningen, 2004 [Medical Advisory]) and it is seen as the result of ignoring for a long time the signals indicating that all is not well in the body or soul. Statistics show that stress and stress-related symptoms have increased significantly in Sweden in recent decades (Sjukvårdsrådgivningen, 2004). Between 1995 and 1999, the proportion of individuals on sick leave due to stress or other psychological strain has increased from close to 5 % to above 7 %. The Committee on Public Health [Folkhälsokommittén] has stated that stress is one of the greatest and fastest growing threats to the health of the Swedish people (Sjukvårdsrådgivningen, 2004).

A reduced level of psychological well being has been noted in somewhere between every third of fourth Swedish adult (Levi, 2002). An expansion of research domains which consider physiological and psychological aspects of stress and pain as well as endocrinological and immunological aspects could pave the way for new insights and new research areas, which hopefully can open doors to a deeper understanding of the mechanisms underlying chronic pain (Melzack, 2005). This idea, in turn, may point the way toward new therapeutic treatments that can limit the suffering.

1.1.2 The stress response

The acute stress response, also labeled “the fight or flight response”, was described by Walter Cannon in the 1920’s. The response was seen as the first step in an adjustment process which regulates stress activity in both animals and man (Cannon, 1915; Cannon, 1932). The response is a protection for the individual and the species in their primitive and ruthless existence and primarily protects the individual against physical danger. There is also a behavioral component coupled with a specific re-adjustment of the autonomic nervous system and of the hormonal system (Ekman & Arnetz, 2002; Folkow, 2002; Kiive, Maaros, Shlik, Toru & Harro, 2004). The purpose of the activity is to make us alert and ready to act through various physical, bodily, and cognitive processes. The four main reactions are (1) the vigilance reaction, (2) the play dead reaction, (3) the alarm reaction and (4) the frustration reaction. If the central nervous system (the CNS) determines that the situation can be overcome, the alarm reaction, primarily, is triggered, entailing specific behaviors and neuro-hormonal adjustments. If however the situation is deemed overpowering, then the frustration/surrender reaction is triggered entailing a different set of behaviors and neuro-hormonal adjustments (Folkow, 2002). During the 1930’s, the endocrinologist Hans Selye demonstrated that stress could lead to deleterious, bodily reactions and that prolonged states of stress could lead to disturbances in the body’s immune system (Gazzaniga & Heatherton, 2003; Selye, 1974). Selye showed that the adrenal glands became enlarged during times of stress (Ekman & Arnetz, 2002; Selye, 1974).

When we experience a situation as threatening, the autonomic nervous system automatically triggers various bodily reactions both in the muscles and the internal organs (Benson, 1975; Lundberg & Wentz, 2004). The sympathetic nervous system prepares the body for either fight or flight and for strenuous, muscular activity. The stress reaction increases the breathing and pulse rates, increases the blood flow to the muscles and reduces activity in the digestive tract. When the blood is re-directed from the digestive tract to the muscles, the body becomes prepared for a taxing and dangerous job. Blood sugar and lipids increase in the blood stream and enable the release of stored energy reserves, necessary in strenuous and dangerous activity (Lundberg & Wentz, 2004). The process is the result of a long, evolutionary development where the sympathetic branch of the autonomic nervous system is activated (Gazzaniga & Heatherton, 2003), while the parasympathetic signals restore the bodily reactions following sympathetic activation. The hypothalamus controls the internal processes and releases a cascade of events in the autonomic

nervous system (the ANS), as well as in the endocrine and immunological systems (Jansen, Nguyen, Karpitskiy, Mettenleiter, & Loewy, 1995). Stress focuses our attention, vigilance increases, the pupils widen, and the body temperature, excitation and arousal increase. The mood changes along with emotional displays, a reduced sense of pain, appetite and sexual desire (Lundberg & Wentz, 2004).

In the case of acute stress reactions, changes take place in the central nervous system (CNS), and the transmission of signals from the brain to the body involves the autonomic nervous system, the neuro-endocrine, as well as the neurotransmitter – neuro-peptide system, the muscular and skeletal systems (Damasio, 1988; Turner, 2000). A variety of hormones included in these systems, e.g. cortisol also affect the functioning of the immune cells and thereby the entire immune system (Ekman & Arnetz, 2002). In the case of increased stress, the level of the 3-methoxy-4-hydroxy-phenylethyleneglycole (the MHPG-level) increases in the blood (Scheinin, Chang, Jimerson & Linnoila, 1983), a metabolic product of norepinephrine, and functions as a transmitter substance as well as a hormone, released during stress (Scheinin et al., 1983; Kjellgren, 2003). The MHPG- level in the blood primarily reflects the activity of the afferent, sympathetic (stress-related) noradrenergic nervous system.

Other hormones such as cortisol are also released into the blood stream during stress, and a prolonged release of the stress hormone entails stimulation of tissues and nerves and can, over time, contribute to the development of chronic states of pain (Nisell & Lundeberg, 1993; Sorensen, Bengtsson, Backman, Henriksson & Bengtsson, 1995). Chronic pain may also entail disturbed or shortened sleep (Gustafsson, 1999, 2002; McGrath, 1994; Rööst & Nilsson, 2002) and the activation of the stress-regulatory hypothalamus-pituitary-adrenal axis (the HPA axis) (Åkerstedt, 2002; Esch, Fricchione & Stefano, 2003). The sympatico-adrenal-medullar system (the SAM system) is an active defense mechanism, a system, which prepares the individual for a fight. Signals travel from the hypothalamus straight into the sympathetic nervous system, and by way of the adrenal cortex epinephrine, norepinephrine and catecholeamines are released and transported in the blood stream to the various organs in order to prepare for fight. The HPA axis is an important coordinator of the endocrine and immunological regulation in the case of either health, stress, or illness (Ekman & Lindstedt, 2002). The activation of stress by the HPA and the SAM affects growth, reproduction, and the metabolism of energy (Keltikangas-Järvinen, 2000). During acute states of stress, the

production of growth hormones is stimulated, but during prolonged stress it is halted (Ekman & Lindstedt, 2002). In the case of an acute stress reaction, cortisol is released into the blood stream leading to a strengthening of the ability to cope (Ghatan, 2002), and attention becomes focused on the danger. Thus, acute stress may have positive consequences for memory during the acute phase. Repeated and prolonged stress, however, inhibits the growth of the dendrites of neurons in the hippocampus, the dendrites that receive and transmit signals in the body. Over time, enduring stress leads to a bio-chemical and physiological imbalance within several bodily systems. Cortisol is released from the adrenal cortex and reaches the brain, and along with other stress-related molecules it co-ordinates our ability to cope with stress. The cortisol affects the metabolism of carbohydrates, lipids, and proteins in all the tissues of the body (Währborg & Friberg, 2002).

Disturbances in the HPA axis involve a change and flattening out of the diurnal rhythm. Cortisol levels, which are either too high or too low across a 24-hour period, indicate a sign of ill health, sometimes seen in individuals with depression, burn-out, fibromyalgia, or cancer (Lundberg & Wentz, 2004). In the case of chronic stress, the catabolic function of the HPA axis increases, resulting in a reduced release of important growth hormones (Folkow, 2002). Studies have shown that elevated levels of cortisol inhibit hypothalamic and pituitary activities leading to a delay in growth, emotional deprivation, disturbances of memory and concentration (Ekman & Lindstedt, 2002; Levi, 2002; Åkerstedt & Kecklund, 2002). Chronic states of stress have a common etiology associated with sleep disturbances, somatic and psychiatric disorders (Crombie, Davies & Macrae, 1994; Fine, Roberts, Gillette, and Child, 1994). Depression and sleep disturbances are also associated with, and correlate with, levels of perceived stress and an elevated level of cortisol in the blood stream (Rööst & Nilsson, 2002). Even feelings of anxiety and fear dominate during stressful situations, and a chronic activation may result in cognitive disturbances, anxiety, and depressed mood (Lundberg & Wentz, 2004).

1.1.3 The relaxation response

Hess (1957) was the person who first described the relaxation response. When he stimulated various areas of the hypothalamus in cats, both fight and flight responses and a physiological reaction opposite to the stress response were triggered. Herbert Benson described the relaxation response in 1975. He labeled it the relaxation response (the RR) and described it as the opposite of the physiological stress response, or the fight or flight response (Benson, 1975).

He argued that the relaxation response is a physical state of deep rest, which changes the physical and emotional response to stress and suggested that all humans have a natural and inborn protective mechanism against “overstress” allowing for a distraction of deleterious effects on the body (Setterlind, 1990). It has been scientifically shown that regularly produced relaxation is an effective treatment method for a series of stress-related disturbances (Benson, 1975). Many illnesses are caused by or worsened by stress (Linton, 1982). He argued that regular use of various kinds of relaxation can alleviate various symptoms and improve the possible development of illness (Benson, 1975).

The relaxation response (the RR) can be elicited through various techniques e.g. meditation, autogenous training (Smith, 1993), Tai Chi (Sandlund & Norlander, 2000), physio-acoustic methods (Norlander, Sandholm & Anfelt, 1998), and biofeedback training (Setterlind, 1990). It has been shown that relaxation is an appropriate and relevant therapeutic instrument for the treatment of a variety of stress-related disorders and medical processes. Relaxation has been shown to have positive effects on immunological, coronary, vascular, and neuro-degenerative disorders as well as on several psychological disorders (Esch et al., 2003). RR exercises and techniques have been shown to inhibit the progression of immunological diseases (Lutgendorf, Logan, Kirchner et al., 2000; Schulz & Kaspar, 1984). The relaxation response has also been shown to have positive effects on blood pressure in patients with coronary inflammation (Munro, Creamer, Haggerty & Cooper, 1988), cardiovascular disease (Julius & Cottier, 1983), sudden cardiac symptoms (Lawn, Verrier & Rabinowitz, 1987), pain (Linton, 1982; Melzack & Wall, 1970), cutaneous disorders (Fava, Perino, Santomastaso & Fornasa, 1989), brain cell death (Roberts & Barnes, 1990), and infertility (Seibel & Taymor, 1985). Uvnäs Moberg (2002) argued that the body contains powerful anti-stress systems which fight stress and increase tolerance for strain. When “anti-stress” dominates, there is peace and quiet, and the energy is used in the anabolic processes. The body energy is used for nutritional storage, growth, and healing (Uvnäs Moberg, 2002).

A variety of hormonal, neuronal mechanisms and mechanisms of the central nervous system determine and transmit the activity of the anti-stress system. Uvnäs Moberg (2002) argued that closeness and support affect us more than we think. A nursing mother becomes calmer and more socially interactive. At the same time blood pressure and cortisol levels drop, while oxytocin and prolactin are released to stimulate lactation, the production of milk. The oxytocin calms, stimulates social interaction, and produces an anti-stress pattern

(Uvnäs Moberg, 2002). Through mechanisms indirectly associated with oxytocin, the activity of the HPA axis is reduced. The activity is slowed down because the oxytocin counteracts the effect of vasopressin and the corticotrophin hormone (CRH) of the pituitary and the brain stem. The release of CRH and the adrenocorticotrophic hormone (ACTH) is slowed down. At the same time, the release of cortisol into the bloodstream is reduced, blood pressure drops, and the anti-stress system is activated. Uvnäs Moberg pointed to two major changes which have taken place in Society. Stress has increased and the stimulation of the calming anti-stress systems has decreased. She has argued that the very strong association among stress, ill health, and a low sense of well-being calls for therapies which reduce the level of stress and also actively stimulate the anti-stress systems contained in the body (Uvnäs Moberg, 2002).

1.1.4 Problems with the elicitation of the RR

There are hundreds of methods for self-change and personal development, and many of them have been around for thousands of years, while others were developed during the 1970's and 1980's (Setterlind, 1990). For some of them the purpose was to elicit the relaxation response, thereby reducing stress and the activity of the autonomic nervous system. In the discussions of the effects of the relaxation response, stress reduction and reduced activity of the autonomic nervous system are repeatedly key features. Techniques such as autogenous exercises (Smith, 1993), Tai Chi (Sandlund & Norlander, 2000), various physio-acoustic procedures (Norlander, Sandholm & Anfelt, 1998), and biofeedback (Setterlind, 1990) are some of the techniques developed to produce relaxation. Even medical treatment aims ultimately to elicit the RR, for example through the use of tranquilizers. However, a purely medical treatment is rarely successful in the treatment of stress-related disorders (Lundberg & Wentz, 2004). Differentiating physical from psychological tension is difficult, as is the treatment of each individually, given the fact that they are both elements of a total reaction during exposure to demands and strains (Setterlind, 1990). Stress-related disorders can, in principle, appear in isolation, such as in elevated blood pressure (Benson, 1975), but typically the symptoms are widened and progress with the result that a strained living situation worsens, and chronic stress increases. This fact can produce a sense of loss of control, helplessness, frustration, and depressed mood (Lundberg & Wentz, 2004). The individual despairs and finds it difficult to take hold of her situation.

In order for a relaxation technique successfully to elicit an RR, at least two factors are necessary, according to Ben-Menachem (1977), i.e. reduced sensory stimulation and reduced bodily movement. Here, one problem is that individuals who are in the greatest need of relaxation exercises are often the individuals who find it the most difficult to participate in the exercises necessary to elicit the RR (Maslach, 1998; Norlander, 1997). Given the difficulty of motivating stressed individuals with an incipient stress symptomatology and diffuse pain to relax using traditional relaxation techniques, alternative treatment and relaxation techniques must be developed. There is also a great need to reduce the risk of drug abuse. Alcohol intoxication, for example, may produce immediate relaxation in a stressed individual (Norlander, 1997), a fact that may explain why anxiety and stress may pave the way for alcohol abuse. It is not a recommendable route, given the well-documented dangers of alcohol use. Instead, safe techniques need to be developed, techniques that both reduce the level of stress and the activity of the autonomic nervous system, and also activate the natural anti-stress systems in the long run (Uvnäs Moberg, 2002).

1.1.5 Flotation-REST

Flotation-REST, Restricted Environmental Stimulation Technique [in Swedish flyt-REST], is a strong candidate for being a method which effectively and safely may elicit the relaxation response even in individuals with heavy stress problems. In flotation-REST the individual rests in a heated “flotation tank” containing salt water holding a water temperature of 34.7 degrees Celsius (Bood et al., 2005; 2006; Norlander et al., 1998). The temperature in the tank is the same as the temperature of the human skin, the purpose of which is to reduce the tactile experience from the environment. Salt water is used to facilitate floating, powerful enough to produce relaxation in an environment of silence and darkness. The darkness and silence during treatment have the effect of reducing sensory input from the external environment (Norlander et al., 1998), and attention is instead directed at the individual’s own world of thoughts, at the body, and at internal sensations. The individual experiences a floating, quiet, and weightless state, sensory isolation. During such sensory deprivation, attention and thinking become more oriented toward primary processing, more intuitive, pictorial, and oriented toward “the here and now”. At the same time, more abstract thoughts and thoughts focused on events in everyday day life diminish. The thoughts take on a different time perspective, and different patterns of thought, a different sense of the body. The bodily sensations from the internal organs and from the vestibular system as well as the tactile and

kinesthetic senses then appear. For many individuals it is an advantageous form of mental and bodily relaxation, once in a while to rest in a state of primary processes (Norlander et al., 1998).

Studies of the flotation-REST treatment have shown that following treatment individuals exhibit reduced stress and pain from muscular tension (Kjellgren, Norlander & Archer, 2001; Kjellgren, 2003; Turner & Fine, 1984). A recent meta-analysis (van Dierendonck & te Nijenhuis, 2005) investigated flotation as a stress-management tool. The study included 25 articles with a total number of 449 participants and the results showed that the flotation technique has positive effects on physiology (e. g., lower blood pressure), well-being and performance. There were, however, some limitations of the original studies (e. g., generally small sample sizes, lack of standardization of the frequency and duration of the sessions) and therefore the available data did not give any information on how many sessions of REST would be desirable for different groups of patients. Additional studies are necessary in order to gain greater knowledge and understanding of the physiological, hormonal, and experiential mechanisms involved in the flotation-REST treatment, in particular with regard to individuals who suffer from long-term stress. It is important to relate pain, muscular rigidity, elevated blood pressure, and a variety of hormonal states to an improved quality of life. The rehabilitation of individuals with stress-related symptoms and disorders also needs to be further developed and improved (Johannisson, 2002; Ekman et al., 2002). Previous studies have also shown that the flotation-REST treatment has positive effects on pain as well as on sleep, anxiety, and depression (Kjellgren, 2003; Turner & Fine, 1984). Additional studies have shown that pain from muscular tension of the neck and back could be alleviated through the flotation-REST method (Norlander, Kjellgren & Archer, 2001).

Future research on the flotation-REST technique needs to become more strongly anchored in theory. It might, for example, be possible to link this research to the neuromatrix theory and the relevant variables of different types of pain, affectivity, anxiety, and depression. It is also important to examine just how the neuromatrix can help explain both the effects of the flotation-REST treatment and of a regularly activated relaxation response. Furthermore, long term effects of the flotation-REST treatment have not been explored extensively (Wallbaum, Rezewnicki, Steele & Sudefeld, 1992).

Paper I is a study in which the effects of the flotation-REST treatment on several different stress-related variables were assessed four months following treatment. Greater knowledge and understanding of the importance of the meeting of the caregiver and the patient, in connection with the treatment of stress and pain are also needed. In addition, we need to explore which variables are important to healing, and what is the importance of the placebo effect and of expectations regarding treatment. In Paper II the importance of attention and the placebo effect for the outcome of treatment was studied. In Paper III the effects of longer periods of flotation-REST treatment was studied. The study investigates patients with stress related pain and other similar ailments. The study investigate whether or not 33 flotation sessions were more effective for stress related ailments as compared to earlier tested program with 12 sessions. Paper IV examined whether and how the combination of therapy and flotation tank could be used to treat patients with severe stress problems.

1.1.6 The purpose of the current thesis

The overarching purpose of the current thesis was to explore the long term effects of a documented treatment program, the flotation-REST technique for the treatment of pain, from the point of view of variables connected to Melzack's neuromatrix theory, and to examine extent of a potential attention-placebo effect in connection with the flotation-REST technique. An additional purpose was to examine whether neuromatrix theory might offer a functional frame for the understanding of the empirical results of the thesis.

1.2 Theoretical perspectives

1.2.1 Melzack's perspective

The Gate Theory of Pain

In 1965, Ronald Melzack and Pat Wall published their work "Pain Mechanisms: A New Theory of Pain" (Melzack & Wall, 1965). They argued that there exists a gate mechanism in the spinal cord which opens and closes, or inhibits, the transmission of pain to the brain. A sensation of pain from a physical sensation is affected by an individual's thoughts and emotions (Melzack & Casey, 1968). Even cognitive, motivational, and affective aspects affect the perception of pain, which in turn can affect the position of the gate (Melzack & Wall, 1982). The most important feature of the theory in terms of understanding pain was its emphasis on the central neural mechanisms (Melzack, 1999). The theory forced medical and biological science to accept the view of the brain as an

active system with filtering and modulating capacity (Melzack, 1999). Phenomena such as phantom pain could not be explained, but the theory was flexible enough to include observations, up until now not known. The spinal gate theory can in part explain the pain reducing effects of certain physio-therapeutic treatment methods such as massage, vibration, high frequency transcutaneous, electrical nerve stimulation (TENS), and acupuncture (Werner & Arnér, 2000). The theory primarily emphasized the gate mechanism and the modulation of pain signals in the spinal cord (Melzack, 2001).

The Gate Control Theory (see Figure 1) is the best known pain theory (Melzack & Wall, 1982). It holds a primarily physiological perspective. The theory has been shown to be incomplete, however. Pain is a complex phenomenon and a multi-dimensional perception varying in quality, strength, duration, localization, and discomfort (McGrath, 1994). More knowledge is needed about the peripherally active, inflammatory processes, the modulating effects in the spinal cord (Melzack, 2001), the association among the function of the mid-brain and the descending pain-inhibiting functions as well as the association with conscious perceptions. Our bodily perception includes cognitive processes along with visual and vestibular mechanisms that need to be included in the theory for an increased understanding of the perception of pain (Melzack, 2001). The complex and multi-dimensional character of the experience of pain needs a more developed theory which includes the cognitive processes as well as the importance of the limbic system for the experience of pain (Melzack, 2001). For this reason, a more elaborate and further refined theory of pain is needed.

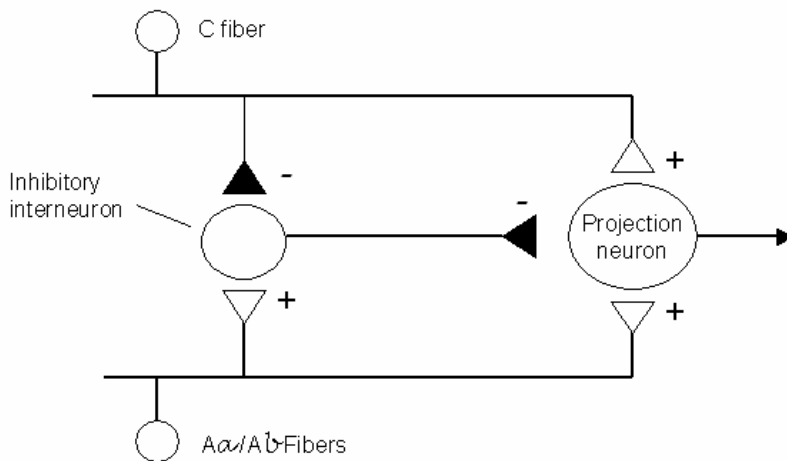

Fig: 1 One explanation for the modulation of pain is the gate control hypothesis. This hypothesis focuses upon interactions of four classes of neurons in the dorsal horn of the spinal cord: (1) unmyelinated nociceptive afferents (C fiber), (2) myelinated non-nociceptive afferents (Aα / Aβ), (3) projection neurons, whose activity results in the sensation of pain, and (4) inhibitory interneurons. The inhibitory interneuron is spontaneously active and normally inhibits the projection neuron, thus reducing the intensity of pain. It is excited by the myelinated nonnociceptive afferent but inhibited by the unmyelinated nociceptor. The nociceptor thus has both direct and indirect effects on the projection neuron. From Kandel, Schwartz & Jessell, (1991 p, 392).

The neuromatrix

Ronald Melzack also developed the neuromatrix theory and it represents a development of his original gate theory about pain (Trout, 2004). The neuromatrix theory assumes that pain is a multi-dimensional experience, produced by a characteristic neurosignature, i.e. a pattern of nervous impulses generated by a significant neural network in the brain (Melzack, 2005). The pattern is triggered by sensory input but also generates qualities of the pain experience independent of the input. Acute pain, elicited by deleterious input of short duration, has been examined by neurological science, and the mechanisms of sensory transmission are generally well known (Melzack, 2005). Meanwhile, chronic states of pain, typically characterized by intense pain without discernible damage or pathology, remain a mystery (Melzack, 2005). Chronic psychological and physical stresses are often associated with chronic pain, although their associations have not been thoroughly examined. The anatomical substrate for the bodily self, according to Melzack, is a broad network of

neurons, consisting of a route between the thalamus and the cortex and between the cortex and the limbic system (Melzack, 2005). The extension of the neuromatrix developed from the more primitive systems of the brain, where the control of the health-maintaining, regulatory systems reside (Craig, 2003). Many areas of the brain are involved in the sensation of pain. The modern scanning techniques, Functional Magnetic Resonance Imaging Technique (fMRI) and Positron Emission Tomography (PET-scan) (Werner & Arnér, 2002) have provided much new knowledge regarding the role of the various brain regions for the experience of pain (Dickenson, 2002). The neural network of the neuromatrix contains parallel somato-sensory, limbic, and thalamo-cortical components which maintain sensorily discriminating, affective, motivational, and appraising, cognitive dimensions in the perception of pain (Melzack, 1999; Turk & Meichebam, 1984). The different systems of the brain involve a great many synchronous activities and transmissions. There are hierarchical systems and stable, intermediary forms with a hybrid quality, which characterize a truly living system (Craig, 2002). Craig argued that the overlap between the area of pain perception and the regions of emotional processes in the brain might explain specific, humanly subjective qualities involved in pain (Craig, 2002). In his opinion, the model has difficulties explaining various sensations of pain caused by sharp points, burning heat, biting cold, painful muscles, cramping, and pain from the internal organs (Craig, 2003).

The neuromatrix consists of an extensive network of neurons which generate patterns, processes, and information from the passing signals, which ultimately creates a bodily sense of a whole, a sensation of a self, and the contents of the neurosignature. Figure 2 summarizes the factors contributing to the pattern of experience from the neuromatrix, factors which also produce the sensory, cognitive, affective dimensions of the experience of pain and pain behavior (Melzack, 2001).

Different kinds of input affect the program of the neuromatrix and contribute to its output. Melzack pointed to important groups of input which affect the matrix and its neurosignature (Melzack, 1999). One important group consists of the sensory input, visual impressions, which affect the cognitive interpretation of the situation, cognitive and emotional input from other parts of the brain, inherent neural, inhibitory, modulating elements, and the activity of the stress-regulatory system of the body, and cytochines such as the endocrine, autonomic, immunological and the opioid system (Melzack, 1999, Wall & Melzack, 2006). Pain-specific neurons have their own special main connections to the brain. The Lamina 1 neuron (i.e. a neuron active higher up

in the brain with further connections to higher, hierarchical levels) is strongly associated with distinct sensations, as reported by individuals who have undergone well-defined pain tests (Craig, 2003). Pain centers, such as the parietal-insular cortex, are important areas for the pain processes of the brain. One area of the parietal-insular cortex receives signals from the Lamina 1 neurons via a specific relay station called the VMpo (the posterior part of the ventral nucleus), and forwards them to the sub-cortical regions. There are researchers, however, who question the localization of this function (Craig, 2003). With pain, there is also significant activity in a different region in the medial, frontal cortex; the caudal, posterior region of the anterior cingulate which controls our motivational behavior. This region is accompanied by an activity in several sub-cortical regions, such as the amygdala, cerebellum and striatum (Craig, 2003).

The neurosignature constitutes a continuous flow from the neuromatrix of the bodily self projecting to the sensing, neural center, where the stream of nervous impulses is modulated and re-shaped into a continuous stream of changed consciousness, and on to activity in the neurons of the spinal cord in order to produce muscle schemas and complex activities (Melzack, 2005). The four components of the new conceptual nervous system are: (1) the neuromatrix of the bodily self, (2) the frequent process and synthesis of the neurosignature, (3) the central perception, which converts and transforms the flow of nervous impulses into a stream of consciousness, and (4) the activation of an active neuromatrix which then creates patterns of movement in order to achieve the sought after goals (Melzack, 2005). The neuromatrix is the source of the neurosignature, organized and shaped in the neuromatrix with continuously changing qualities.

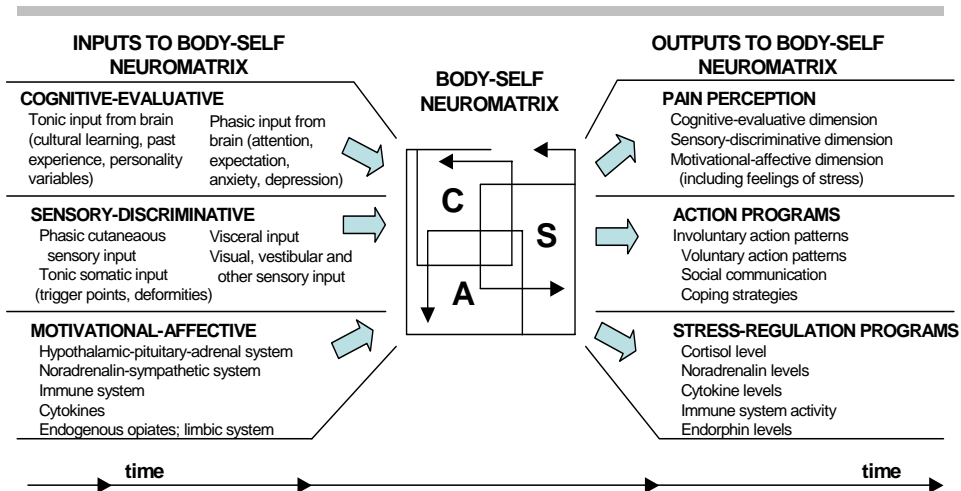

Fig. 2. Factors that contribute to the patterns of activity generated by the body-self neuromatrix, which comprises sensory (S), affective (A) and cognitive (C) neuromodules. The output patterns from the neuromatrix produce the multiple dimensions of pain experience as well as concurrent homeostatic and behavioral responses. (From: Melzack R (1999) Pain Suppl. 6: s121-6)

The expansion of the research area of pain toward the inclusion of endocrinology and immunology could lead to new insights and new research involving the revelation of the mechanisms underlying chronic pain and the possibility of new therapeutic methods which could reduce the tragedy of severe and unnecessary suffering (Melzack, 2001). The logical extension of Melzack's perspective is that a regularly activated relaxation response – due to its broad and all-encompassing character at both the somatic and the psychological level – could affect the different systems, i.e. the neurological, endocrine, and immunological systems, and re-organize the quality of the neuromatrix, such that a new, qualitatively different neurosignature is formed. Important expressions of the neurosignature could be captured with different psychological instruments which measure degree of stress, energy, emotions, anxiety, depression, pain etc. Various types of physiological instruments assessing different physiological parameters, or expressions of the neurosignature, could also be used. Even qualitative aspects, norms, and evaluations, such as the experience of the different dimensions of stress and stress treatment, could be used in the delineation and interpretation of the

neurosignature before, as well as after, treatment. According to Melzack (2005), we do not learn from the qualities of our own experiences: our brain is built to produce them.

1.2.2 The perspective of Bergström

Bergström viewed the brain as a bi-polar system (Bergström, 1990) with an entropic and a negentropic pole. Entropic refers to disarray, chaos, mess, but also to the power which chaos can exert in an energy field of order. The field of energy generates energy, according to Bergström. At the entropic pole, the primitive brain stem, chaotic signals travel upward to the brain, while the negentropic pole, the highly developed cortex, transmits orderly signals downward. The streams of signals meet in the limbic system in the mid-brain (MacLean, 1973). Through emotions and values, the neuro-mental self is formed at the intersection of the two poles. The self, according to Bergström, is a space with two dimensions; one real dimension depicting the sensory input from the individual's physical environment, and an imaginary dimension depicting the flow of signals from the chaotic brain stem, the internal feelings and values of the brain (Bergström, 1995). The real dimension depicts what we "know" about our physical environment, and the imaginary dimension reveals what we "feel", our internal existence (Bergström, 1990). The real/imaginary space of the self reflects the situation in which the individual is at the time, her environment. Bergström called this space "the complex number space" (Bergström, 1990).

In the meeting between the two poles a "fractal Mandelbrot space" is created (Bergström, 2006), where there are processes which are not based on logical laws of Nature but on competitive dynamics, which follow entirely different principle than logical ones as well as the chaotic states. Lagerroth labeled them selection and collection (Lagerroth, 2006). Order is broken down into chaos in order once again to be built up as order in accordance with the function of creativity. The two dimensions reflect the unconscious and the conscious (Bergström, 1990). Due to the fact that Man's self is a Mandelbrot space, the possibility of uniting imaginary aspects and real aspects, order and chaos. Bergström argued that chaos is a normal feature of Man and necessary for human life (Bergström, 1990). In the energy field between conscious and unconscious processes, as well as between order and chaos, transformations take place which continuously re-shape experience. Bergström (1992) suggested that Man's self is the result of the forces of the conscious and the unconscious, or between order and chaos. A balance self

requires well-developed imaginary and real processes in the brain (Bergström, 1992). The tension produces a creative transformation and interpretation of the various sensations. Every sensory experience, every movement and activity performed, will be coded into the pattern of the brain synapses, a pattern which adjusts to our needs and the demands of the environment. This notion is also the reason why Bergström became interested in Developmental Psychology and Neurology Education, is the reason theory is used by people working with movement training in children (Sohlman, 2000).

The development of the brain's pattern of synapses starts as early as during the prenatal period, e.g. the development of hearing and the neural systems for movement and physical sensations. There is also a powerful, electric activity in the retina during the prenatal stage. Eyes not used become blind (Sohlman, 2000). The vestibular system also develops as early as during the ninth and tenth week of gestation and is more or less complete by the fifth or sixth month of gestation. This system facilitates keeping track of what is up and what is down and the positioning of the head. The system becomes stimulated when the infant is cradled and rocked (Sohlman, 2000). The brain of the newborn infant is small. It weighs 400 grams, whereas an adult brain weighs approximately 1.5 kilograms. The implication is that the most intense period of growth of the brain takes place during the first few years following birth (Sohlman, 2000). It is at this time that the nerve cells and synapses necessary for learning and development have their growth spurt. The brain is characterized by plasticity and is influenced by external events, in particular during childhood. All the cells and synapses whose growth has begun can develop further throughout life. Matti Bergström once said: "Once you have walked and made paths, these paths can become highways later in life" (Sohlman, 2000). The development of balance rests on the interaction of a series of senses; the kinesthetic, the tactile, and the visual senses. Reflexes are also important for development and learning. Motor ability is a prerequisite for learning (Sohlman, 2000). Several of the senses developed early, feelings and remaining fetal and infant reflexes, may be re-experienced in a temporarily weightless and stimulus-free environment, and may be examined and further developed in adulthood.

1.2.3 The primary and secondary processes

There are similarities between Bergström's theory of order (the cortex) and chaos (the brain stem) on the one hand and the classical psychological concepts of primary and secondary processes. These concepts originate in classical psychology. Freud used the concepts to describe how men's central drives

express themselves. He argued that the id contains drives which push to express themselves and seek immediate and unconditional satisfaction in accordance with the pleasure principle (Hwang, Lundberg, Rönnerberg & Smedler, 2005). The central drives, the sexual drive and the aggressive drive, express themselves cognitively as a type of primary process thinking; a type of thinking determined by the pleasure principle without the consideration of logical rules or without being anchored in reality. Dreams are an example of such thinking. Wishful fantasies such as fantasies of revenge also contain this type of thinking. In primary process thinking such as in dreams sometimes condensations appear (Hwang, et al., 2005). A condensation can give a person character traits, which are a mix and a combination of many different people. Displacements also occur. A displacement involves an individual gaining features actually belonging to someone else.

Secondary process thinking refers to logical, problem solving, reality testing thinking which is capable of fulfilling drives in a way adjusted to reality, while at the same time securing life and well-being in the best possible way (Hwang, et al., 2005). The orthodox, psychoanalytic interpretation of primary and secondary processes has been criticized by subsequent writers, who maintained that the two types of processes are rarely separate but appear mixed and change into different combinations (Neisser, 1997; Noy, 1969). Experiments on sensory deprivation have shown that under such conditions primary process cognition is prevalent (Goldberger, 1961). Based on these experiments, Noy defined the two types of processes: “secondary processes are all mental processes dependent on feedback for their maintenance; primary processes are all mental processes not dependent on feedback for their maintenance” (Noy, 1969, p. 166).

Norlander (1997) used the concepts of primary and secondary processes to describe the flow among conscious, preconscious, and unconscious processes. In his work a broader model of the interaction among the processes was used (Norlander, 1997). According to the “four perspectives model”, the FP-model, the creative and conscious processes oscillate between secondary and primary states. In this respect, there are major similarities to Bergström’s view of the developmental processes regarding creativity as emotions and their interpretation. According to the FP-model the oscillation is between two states, which at the same time vary in content. Thus, the ongoing oscillation between the different processes is also characterized by an ongoing change in quality over time. What is chaotic, timeless is followed by order which is followed by chaos which is followed by order of a different kind.

According to the FP-model, the development can be described as sequences appealing to primary or secondary processes in different ways. Norlander (1997) described this process in sequences. The process starts with a preparation containing secondary features followed by a primary stage labeled incubation. The incubation is then transformed into a new phase. Again, there are similarities to Bergström's description of how the brain combines two disparate aspects into a new insight. Norlander labeled this sequence illumination. The new insight has features of secondary process thinking (Norlander, 1997). The insight is then transformed into verification, also with features of secondary process thinking. Following verification, there is order followed by primary process thinking, the latter characterized by recovery as well as stress- and tension reduction (Norlander, 1997).

There are many techniques available for the facilitation of shifts between primary and secondary processes. Some of them include humor, hypnosis, neuro-muscular relaxation, autogenous exercises, meditation, biofeedback training, and flotation-REST (Norlander, 1997). During flotation-REST treatment, secondary processes diminish leading to a cognitive shift favoring primary processes (Norlander, Bergman & Archer, 1998). The relaxation response and the anti-stress system are also activated during the flotation-REST treatment. These changes (in the neuromatrix) can be recorded on psychological tests, physiological measures, and on measures of stress-related markers in the blood (Melzack, 2001).

2. THE PRESENT INVESTIGATION

2.1 Introduction

In this section the purpose, design, instruments, procedures, statistics, and results of the four articles contained in the thesis will be discussed. All in all, 125 individuals, 97 women (77.6 %) and 28 (22.4 %) men, participated in the four studies, which spanned the years 2003 (April) and 2005 (December). The participants' mean age was 49.42 (SD = 9.34). Of the patients 48 (38.4 %) were diagnosed as having burn-out depression.

Each participant first met a pain specialist at the initial medical examination where they were informed about the project, screened for suitability through questionnaire 1 and underwent a medical examination, plus a careful pain analysis, including palpation of muscle tone and a neurological examination. Among the exclusion criteria were listed pregnancy or ongoing breast feeding, somatic problems/illnesses requiring other types of treatment, open wounds, manifest psychiatric symptoms, neurological disturbances, whiplash-related disorders, manifest posttraumatic stress disorder, as well as regular treatment with heavy opiate analgesics, signs of anxiety/fear, or discomfort being in a restricted environment. During this interview, each participant's degree of anxiety-depression was assessed using HAD. Every participant received a leaflet with patient-oriented information about flotation-REST, wherein (in addition to the purely practical details associated with treatment) they were also informed that driving was not recommended shortly after treatment (due to increased risk of transient tiredness). During this initial contact each subject was shown around the floatarium.

Given the fact that the participants appeared for the experiments after varying lengths of time, they were asked once again to complete Questionnaire 1 and the HAD-test immediately prior to the first flotation session. This was done in order to ensure comparable baseline values. At this time they were also asked to complete the remainder of the tests. All blood assays were done at the Public Health Center (Kronoparken) adjacent to the Human Performance Laboratory three days (or 72 hours) prior to the first flotation session, and three days after the last flotation session, respectively.

2.2 Paper I. Flotation-REST with follow-up

2.2.1 Aim

The purpose of the study was to explore whether it was possible to replicate earlier findings of increased well-being after flotation tank therapy and to investigate whether or not those improvements were maintained during a follow-up four months later.

2.2.2 Design

The current study in a first step used a three-way split-plot design, where Time with assessments before and after the treatments constituted the within-subjects factor and where Group (Control, Flotation-REST) and Diagnosis (Non-burnout patients with stress-related pain, burnout patients with stress-related pain) constituted the between-subjects factors. The participants were randomly assigned, in equal numbers, to the control (20 non-burnout patients, 15 burnout patients) or flotation (24 non-burnout patients, 11 burnout patients) groups. Participants in the flotation-REST group were involved in a total of twelve flotation REST treatments (two times per week during six weeks). The control group received the same treatment as the flotation group before and during the experiment, but instead of floating they sat in an armchair for 45 min. In a second step a two-way split-plot design was used on the flotation-REST group, where the within-subjects factor now also included a 4-month follow up for the flotation group (Treatment condition) and where Diagnosis was maintained as the between-subjects factor.

2.2.3 Instruments

Flotation Tank

A flotation tank (Delfi, www.kikre.com, Varberg, Sweden) measuring 2700 mm x 1500 mm x 1300 mm was used. The depth of fluid (salt water) varied between 200-to-300 mm. The flotation tank was insulated to maintain constant air and water temperature and to reduce incoming light and noise. The water temperature was maintained at 34.7°C and was saturated with magnesium sulphate (density: 1.3 g/cm³). The tank was equipped with a horizontal entrance that was easy to open and close (from inside and out) by the subject. Between flotations, a hydrogen peroxide solution was regularly poured in, and after this the salt water was filtered and sterilized with UV-light.

Questionnaire 1

Before the treatment (floating in the tank) a questionnaire was provided that estimated each subject's self-assessed pain: intensity, frequency, duration, onset, sleep quality, treatment as well as experiences/symptoms of other types of complaints. Each subject's own descriptions of "Sleep Quality" were estimated on visual analogue scales (0-100).

Questionnaire 2

At a final meeting directly after the seven weeks of the experimental flotation procedure, the same questions were presented as in Questionnaire 1.

Blood measures

In the present study blood samples were taken for cortisol and prolactin between 10 o'clock AM and 2 o'clock PM. According to laboratory standard procedures, cortisol was measured in nanomol per liter blood serum (nmol/L) and prolactin was measured in microgram per liter blood serum (ug/L). Normal range for cortisol 10 o'clock is 125 – 625 nmol/L. Normal range for prolactin concerning men is 3.5 – 18 ug/L, and for women 4.5 – 25 ug/L. Appropriate markers that are stress related as cortisol and prolactin were analyzed. The handling of blood tests, taking blood tests and storing was done in collaboration with Kronoparkens Health Care Center and Kemiska laboratoriet (Kem Lab) at Centralsjukhuset in Karlstad (CSK), where the tests were analyzed.

PAI - Pain Area Inventory

The test, which was constructed for the current thesis consists of two anatomical images of a human being, one frontal and one dorsal. The task of the participants was to indicate their areas of pain. A transparent, plastic film was then placed over the areas on both figures. Each figure was divided into 833 equal-sized squares (total 1666), and the number of marked squares was calculated. The test was validated through comparisons with other instruments measuring total number of pain types, number of connected pain areas, most severe pain intensity, normal pain intensity, and pain frequency which yielded acceptable values (standardized item alpha = 0.84, R = 0.70). Test-Retest reliability was examined through using a group of pain patients who completed the PAI on two occasions, seven weeks apart ($r = 0.92$).

SE - Stress and Energy

The SE instrument is a self-estimation instrument concerning individuals' energy and stress experiences (Kjellberg & Iwanowski, 1989). It consists of two subscales that elucidate the mood levels of the subjects on the dimensions: 'experienced stress' and 'experienced energy'. The instrument has been validated by analyses from studies focused on occupational burdens and pressures (Kjellberg & Bohlin, 1974; Kjellberg & Iwanowski, 1989). The SE-scale was constructed and based on an early and much used checklist, the Mood Adjective Check-List, constructed by Nowlis and Green (1965) and modified further and translated into Swedish by Kjellberg and Bohlin (1974). Kjellberg and Iwanowski (1989) reduced the list to 12 adjectives on two dimensions. It is currently the latest version of the SE-scale (with test-retest scores of 0.73 to 0.78) and was used in the present study.

HAD - Hospital Anxiety Depression Scale

The HAD is a rating scale concerning degree of anxiety and depression, using various published materials. It was constructed by Zigmond and Snaith (1983), for use with physically ill people. It has since been revised to be used as a rating scale for anxiety and depression. Its validity and reliability were examined by Herrmann (1997). The instrument consists of fourteen statements with four response alternatives (0 to 3), ranging from positive to negative or vice versa, and there are seven statements regarding anxiety and seven regarding depression.

LOT - Life Orientation Test

This test (Scheier & Carver, 1985) consists of eight items, plus four filler items. The task of each participant is to decide whether or not one is in agreement with each of the items described, on a scale of 0 - 4, where 0 indicates, "strongly disagree" and 4 indicates "strongly agree." The test measures dispositional optimism, defined in terms of generalized outcome expectancies. Parallel Test Reliability is reported to be 0.76 and Internal Consistency to be 0.76 (Scheier & Carver, 1985), Test-Retest reliability is 0.75 (Norlander, Bergman, & Archer, 2002). LOT is also regarded as having an adequate level of convergent and discriminant validity (Scheier & Carver, 1985), as demonstrated by correlation statistics and by using LISREL VI ($r = 0.64$).

PANAS - Positive affect and Negative Affect Scales

The PANAS-instrument (Bood, Archer & Norlander, 2004; Norlander, Bood, & Archer, 2002; Watson, Clark, & Tellegen, 1988) assesses the degree of affect, both negative (NA) and positive (PA). The instrument consists of 10 adjectives for the NA-dimension and 10 adjectives for the PA-dimension. In the test manual (Watson et al., 1988), it is postulated that the adjectives describe feelings and mood. The participants were asked to estimate how they had been feeling during the last week. Response alternatives are presented on 5-degree scales ranging from 0 = “not at all” to 5 = “very much.” The PANAS-scale has been validated through studies focused upon several different routinely used scales within psychopathology (Huebner & Dew, 1995, Kercher, 1992). Cronbach’s alpha for PA was 0.73 and for NA 0.76, in the present study.

EDN – Experienced Deviation from Normal State

An instrument modified for use with flotation-REST (Kjellgren et al., 2001) utilizes the internationally applied psychometric instruments APZ-questionnaire and OAVAV (Dittrich, 1998) for obtaining judgments of altered states of consciousness and the relaxation response. Several studies indicate strong connections between altered states of consciousness and different RR techniques such as Qigong (Jones, 2001), Tai Chi (Yocum, Castro, & Cornett, 2000), and muscle relaxation training (Stenstrom, Arge, & Sundbom, 1996). In total, the EDN instrument consists of 29 questions whereby each is responded on a visual analog scale (0-100). A complete “index of experience” was constructed from the points obtained from all 29 questions and were averaged to provide a “sum of experience.” These values reflect the total experience of deviation from normal states. Cronbach’s alpha for EDN was 0.93 in the present study. Typical EDN-values after an individual’s first experience of flotation-REST is around 30 EDN-points, which should be compared to the first experience of chamber-REST (15 points) (Norlander, Kjellgren & Archer, 2003; Kjellgren, Sundequist, Sundholm, Norlander, & Archer, 2004).

2.2.4 Procedure

The participants were recruited by asking patients on the waiting list for participation in the flotation-REST experiment at the Human Performance laboratory, Karlstad University, Sweden. They were either originally referred by their physicians or had responded to announcements for individuals suffering

from localized muscle tension pain in the neck and shoulder area, with or without temporal headache, associated with myofascial tender points or trigger points. Each participant's first contact with the project was an interview with a pain specialist at the initial medical examination where they were informed about the project, screened for suitability through questionnaire 1, and underwent a medical examination, plus a careful pain analysis, including palpation of muscle tone and a neurological examination. Among the exclusion criteria were listed pregnancy or ongoing breast feeding, somatic problems/illnesses requiring other types of treatment, open wounds, manifest psychiatric symptoms, neurological disturbances, whiplash-related disorders, manifest posttraumatic stress disorder, as well as regular treatment with heavy opiate analgesics, signs of anxiety/fear, or discomfort being in a restricted environment.

Participants were randomly assigned to either the control group or to the flotation-REST group. The participants belonging to the control group sat in an easy chair reading their own literature or literature provided, for 45 minutes, twice per week, first for three weeks, then a week with no treatment, followed by another three weeks with the armchair condition. The participants belonging to the flotation-REST group were given flotation treatment during the forthcoming three weeks (with 2 visits/week), whereby each floating session was of 45 minutes duration. After that the participants had one week with no treatment, followed by another three-week period. The number and duration of treatments — 12 over a 7-week period (two 3-week treatment periods with a non-treatment week in between) — was chosen from similarly sized schedules described in the literature and from our own experiences. Treatment was terminated after 45 minutes when the experimenter gently knocked on the exterior of the tank. Directly after the first session in the flotation tank the participant was allowed to complete the EDN. They also had to complete the EDN test directly after the last session (i.e., after 12 flotation) in the flotation tank.

Three days (or 72 hours) after the final control or flotation session, participants attended a final consultation and follow-up discussion with a nurse, at which time they completed Questionnaire 2 and the personality tests, and a new blood sample was taken. All the patients described in the present study completed the whole course of treatment (12 control or flotation sessions over 6 weeks). Four months after the final consultation all patients in the flotation-REST group were invited to participate in a follow-up study at the Human Performance laboratory. The information was also given that if they accepted

the invitation they would receive a lottery ticket valued at \$10 US. Twenty-eight of the participants in the flotation group participated in the follow-up consultation where they once more completed the questionnaire, the personality tests, and also had a new blood sample taken.

2.2.5 Statistics

A three-way mixed Pillais MANOVA was carried out with Time (before, after) as the within-subjects factor and Group (Control, Flotation-REST) plus Diagnosis (non-burnout patients, burnout patients) as between-subjects factors, and with prolactin, cortisol, pain area (PAI), sleep quality, dispositional optimism (LOT), stress (SE), energy (SE), anxiety (HAD), depression (HAD), positive affectivity (PANAS), and negative affectivity (PANAS), as the dependent variables. In a second step, the long-term effects of flotation-REST treatment were analyzed. Statistical analyses were carried out using two-way split-plot Bonferroni ANOVAs with Treatment (before treatment, directly after treatment, four months after treatment) as the within-subjects factor, and Diagnosis (non-burnout patients, burnout patients) as the between-subjects factor. Only dependent variables which in the first step exposed effects from the flotation REST treatment, shown by Time x Group interaction effects, were used, including, prolactin, pain area (PAI), sleep quality, dispositional optimism (LOT), stress (SE), anxiety (HAD), and depression (HAD).

2.2.6 Results

The effects of a standardized treatment round were examined, whereupon a follow-up was conducted to explore the long-term effects of the treatment. The results showed that the treatment (12 sessions) had the effects of reducing the extent of the pain, perceived stress, anxiety, and depression, and that the quality of sleep and optimism increased. The effects were still present 4 months following the end of treatment. In this context, two stress-related markers were also examined, namely cortisol and prolactin in the blood. Due to the blood assay routines, the outcome of the cortisol measurement was most likely affected, making a correct analysis difficult. The level of prolactin, not affected by the routines, pointed to significant changes between the two measurement points. During treatment the level of prolactin increased by 33 %. At 4 months follow-up several of the positive effects remained, whereas the level of prolactin had returned to its initial level.

2.3 Paper II. Flotation with normal or high attention.

2.3.1 Aim

The purpose of the current study was to examine the possible effects of attention-placebo on flotation tank therapy, how the experience of pain, sleep, anxiety, depression and different stress-variables are affected by attention as well as float-REST.

2.3.2 Design

Thirty-two patients, 25 women and 7 men, recruited from the waiting list at the Human Performance Laboratory at Karlstad University, participated in the study. They had been diagnosed as having stress-related pain, of a muscle tension type. Among the patients, 16 of them also had received the diagnosis of burn-out depression. Half of the 32 patients received special attention for a total of 12 weeks (high attention), while the other half received this attention for 6 weeks (normal attention).

2.3.3 Instruments

In this study the same instruments were used as in Paper I. Blood assays were not obtained.

2.3.4 Procedure

In the present study a High attention group was recruited by asking 20 patients, when they just were finishing their participation in a control group (Paper I), whether they would be willing to continue immediately with a new experiment involving the flotation tank. This means that they were not asked at the same time but rather when their participation in the Control group was to finish. They had not been told prior to the first experiment that they would have the option of receiving flotation therapy after the control sessions had ended. All of the patients agreed to participate directly in a new experiment, but four of them cancelled due to lack of time, immediately before the experiment or in the beginning of treatment. Thus, the group consisted of 16 participants. Given that they had already participated in a control group, they had regularly visited the laboratory and met the staff at the same extent as the flotation group (normal attention). On those occasions, they sat, alone in a closed room, in an easy chair reading their own literature or literature provided, for 45 minutes, twice per week, first for three weeks, then a week with no treatment, followed by another three weeks with attention. In the new experiment the participants

immediately continued with the flotation-REST treatment and with identical treatment intervals (i. e., twice per week for three weeks, then a week without treatment, followed by a final three-week period) along with continued visits with the staff as before. The nature of attention (i. e. associating with the staff) the group received was the same across the first and second 12 sessions, even though the activity alone in a closed room (i. e., armchair or flotation-REST) differed. Thus, this group received flotation treatment 12 times and attention on 24 occasions during a period of 12 weeks.

The other group (Normal attention) had not had any previous contact with the laboratory but was randomly recruited straight from the patient waiting list as described above. The procedure was complete when 16 people agreed to participate in the experiment, and who, according to a nurse fulfilled the criteria for inclusion/exclusion. Subsequently two individuals dropped out, one for lack of time and the other due to his experience of being shut in, in the tank at the beginning of the flotation-REST treatment. Two additional individuals randomly picked from the waiting list then replaced them. All in all, this group also received 12 treatments during a period of six weeks, but attention only at the time of their 12 tank visits.

All participants were given flotation treatment during the forthcoming three periods (with 2 visits/week), whereby each floating session was of 45 minutes duration. After that the participants had one week with no treatment, followed by another three-week period. The experimenters at the flotation site were ignorant of the group identity of each participant and thus to all purposes experimentally-blind. Treatment was terminated after 45 minutes when the experimenter gently knocked on the exterior of the tank. Three days (or 72 hours) after the final treatment session participants attended a final consultation and follow-up discussion, at which time they completed Questionnaire 2 and the psychological tests. All the patients described in the present study completed the whole course of treatment (i.e. twelve sessions over six weeks).

2.3.5 Statistics

Statistical analyses were carried out using three-way split-plot ANOVAs with Treatment as the within-subjects factor and Attention and Diagnosis as between-subjects factors, and with the number of different ways of measuring subjective pain, blood pressure (mmHg), heart rate, alcohol and medicine consumption, and with the psychological variables derived from four personality tests as the dependent variables, i. e., stress (SE), energy (SE),

anxiety (HAD) and depression (HAD), dispositional optimism (LOT), positive affectivity (PANAS), and negative affectivity (PANAS) as the dependent variables. Further statistical analyses were conducted with help of the Chi-Square test in order to find out how many participants used medication prior to, or after, the treatment, respectively.

2.3.6 Results

The purpose was in a more in-depth manner to study the influence of attention on the treatment and the development of pain. In addition, the psychometric characteristics of a newly constructed test were assessed, the Pain Area Inventory (PAI). The PAI was validated by comparing the current results with other ways of assessing pain: intensity, frequency, combined areas of pain, and number of different types of pain. The study showed, as in Paper I, a number of significant improvements. Of the 32 patients, 7 (22 %) became pain-free, 18 (56 %) reported less pain, 6 (19 %) reported no major change, and one person described worsened pain on the chart of pain areas. A reduction of anxiety, depression, perceived stress, and negative affectivity was also apparent following treatment, while optimism, energy, and positive affectivity increased. In general, there were no differences between the group that received extra attention and the group that received a normal amount of attention during their visit to the Human Performance lab. There were, however, two differences: patients without burn-out depression who received extra attention displayed the greatest reduction of their worst imaginable pain, and all those receiving extra attention exhibited a smaller increase in optimism. These results were interpreted as the fact that an attention-placebo does not have a great impact on the flotation-REST treatment itself.

2.4 Paper III. Flotation with 12 or 33 sessions.

2.4.1 Aim

The aim of the study was to investigate whether or not longer periods of flotation-REST treatment give better effects for patients with stress related pain and other similar ailments as compared to the earlier tested program with 12 sessions.

2.4.2 Design

Thirty-seven patients, 29 women and 8 men, recruited from the waiting list at the Human Performance Laboratory at Karlstad University, participated in the

study. They had been diagnosed by a physician as having stress-related pain, of a muscle tension type. They reported having had pain for many years and 23 of the patients took analgesics on a regular basis. Among the patients, 14 of them also had received the diagnosis of burn-out depression. The patients were randomized into one of two conditions: 12 flotation-REST treatments or 33 flotation-REST treatments.

2.4.3 Instruments

In this study the same instruments were used as in Paper I and Paper II but additionally also a “pain matcher” was used. Blood assays were not obtained. The Pain Matcher is a test with electrical stimulation of the skin producing magnitude matching, i.e., a unit that gives constant current stimulation (Cefar Matcher AB, Lund, Sweden). The device is controlled by a microprocessor that provides rectangular pulses with a frequency of 10 Hz and amplitude of 10 mA. The instrument is supposed to give accurate assessments of pain levels experienced by suffering patients. Psychometric investigations indicate excellent reliability scores for pain thresholds (ra between 0.95 – 1.00) but the validity of the instrument concerning assessments of pain levels has not been adequately determined (Alstergren, & Förström, 2003; Stener-Victorin, Kowalski, & Lundeberg, 2004).

2.4.4 Procedure

Each participant’s first contact with the project was an interview with a pain specialist at the initial medical examination where they were informed about the project, screened for suitability through questionnaire 1, and underwent a medical examination and a careful pain analysis, including palpation of muscle tone and a neurological examination. Every participant received a leaflet with patient-oriented information about flotation-REST, wherein (in addition to the purely practical details associated with treatment) they were also informed that driving was not recommended shortly after treatment (due to increased risk of transient fatigue). During this initial contact, each subject was shown around the floatarium. The information was restricted (no mentioning of possible changes in consciousness), and the participants were only informed that most people experience the floating as relaxing.

Following this informational session, participants were randomly assigned to either the 12 treatments flotation group or the 33 treatments flotation group. The participants belonging to the 12 treatments group were given flotation treatment during 2 three-week periods (with 2 visits/week), whereby each

floating session was of 45 minutes duration. The number and duration of treatments, i.e. twelve over a seven-week period, were chosen based on our own experiences. The participants belonging to the 33 treatments group were first given exactly the same treatment (i. e., 2 three-week periods with 2 visits/week) and after that they participated in 7 additional periods but now only one visit/week. A spontaneous procedure consisting of 'first come, first assigned' method was applied. When the participant was using the flotation tank at the very first session, he/she was informed of the flotation technique, shown the bathroom and shower, and thoroughly reminded of their complete freedom to terminate the session if necessary. Following visits to the bathroom and shower and the insertion of earplugs, each participant was allowed to immerse himself/herself in the water of the tank and close the lid unaided, following instructions to relax. Treatment was terminated after 45 minutes.

Three days (or 72 hours) after the final treatment session participants attended a final consultation and follow-up discussion, at which time they completed Questionnaire 2 and the psychological tests. All the patients described in the present study completed the whole course of treatment (i.e. twelve sessions or thirty-three sessions).

2.4.5 Statistics

Statistical analyses were carried out using a three-way mixed Pillais' MANOVA with Tests (before, after) as the within-subjects factor and Treatment (12 treatments, 33 treatments) and Diagnosis (non-burn-out patients, burn-out patients) as between-subjects factors, and with the number of different ways of measuring subjective pain (i. e., lower pain threshold, upper pain threshold, the PAI, number of comprehensive pain areas, most severe pain intensity, normal pain intensity and pain frequency) as the dependent variables.

The stress-related psychological variables were analyzed using a three-way mixed Pillais' MANOVA with Tests (before, after) as the within-subjects factor and Treatment (12 treatments, 33 treatments) and Diagnosis (non-burn-out patients, burn-out patients) as between-subjects factors. Dependent variables were the psychological variables which in earlier studies (e. g., Norlander, Johansson, & Bood, 2005) have been proven to be strongly intertwined, i. e., stress (SE), energy (SE), anxiety (HAD) and depression (HAD), dispositional optimism (LOT), positive affectivity (PANAS), negative affectivity (PANAS), and sleep quality (VAS-scale).

2.4.6 Results

Analyses of subjective pain showed that the number of comprehensive pain areas significantly dropped after 33 flotation sessions but not after 12 sessions. However for upper pain threshold, the PAI, most severe pain intensity, normal pain intensity, and pain frequency, 12 sessions were enough to get considerable improvements and no further improvements were noticed after 33 sessions. A similar pattern was observed concerning the stress-related psychological variables. After 12 flotation sessions the experienced stress, anxiety, negative affectivity and depression decreased, while dispositional optimism and sleep quality increased but there were no further improvements after 33 flotation sessions. Concerning measurements of blood pressure, earlier findings have indicated conflicting results after 12 sessions (Bood et al, 2005; Bood et al, 2006). In the present study no effects were observed after 12 flotation sessions, but there was a significant effect for diastolic blood pressure after 33 sessions.

As expected, the patients with the diagnosis of burn-out depression exhibited significantly higher values on depression and negative affectivity as compared with patients without such a diagnosis. Subsequently it was the depressed patients who showed the significant improvements in regard to depression and negative affectivity. There were no other interaction effects between Tests and Diagnoses, but the patients with burn-out depression had lower values on energy, optimism and higher on anxiety as compared to patients without such a diagnosis.

2.5 Paper IV. Flotation combined with therapy.

2.5.1 Aim

The purpose of the study was to examine whether and how the combination of therapy and flotation tank could be fruitfully used to treat patients with severe stress problems.

2.5.2 Design

Two women on long-term sick leave, aged 55 and 58, participated in the study, which was carried out over a period of one year. One of these women was diagnosed as suffering from burnout depression and the other from fibromyalgia. The therapy program included several components: (a) flotation-REST treatment at least once every other week for 45 minutes on a total of 35 occasions, (b) group therapy on eight occasions, (c) conversational therapy on

eight occasions and (d) picture therapy on eight occasions. The group, conversational, and picture therapy sessions were run in a total of eight meetings.

2.5.3 Procedure

Before the project started, the interviewers and the respondents discussed the organization of the project and how the data would be gathered. They agreed (a) that the clients would be interviewed on two occasions and that the interviews would be taped, (b) that the clients would keep a journal of their experiences in the flotation tank, (c) that they would paint a picture of their experiences in connection with each therapy occasion and (d) that their comments on their own paintings would be taped. Further, it was agreed that everything would be treated confidentially, i.e. that only the two therapists would listen to the material that had been recorded and read the journals. The clients were also informed that they had the right to terminate the interview at any time without giving a reason and without having it affect their treatment. Finally, it was agreed that the material that had been collected could be used as a basis for publication at a later time, on the condition that the anonymity of the clients be guaranteed.

The interviews varied in length between 60 and 80 minutes and the first interview was conducted about halfway through the project, whilst the second interview was held just before the conclusion of the project. During the interviews only one interviewer and one respondent were present. On the second occasion the interviewers exchanged clients. The questions on which the interviews were based enabled the respondents to digress and embellish freely at the same time as there was a central theme running through the conversation. The journals were written up at home the week after the flotation and sent by e-mail to the respective therapist. Now and then the clients floated a little more frequently than every two weeks and the experiences from these occasions were also noted in the journals.

2.5.4 Processing the data

The Empirical Phenomenological Psychological Method (EPP-method) devised by Gunnar Karlsson (1995) was used in processing the data. The method entails an analysis in several stages including techniques for dividing the texts into smaller so-called "meaning units" (MU). This division is not based on grammatical rules but entirely on the content the researcher discovers and where there is a suitable shift of meaning. The analysis yielded 238 meaning

units, which generated 12 categories. Each category illustrated a special perspective of the phenomena studied. To control for the reliability of the results of the study, a credibility test for phenomenological analysis was used (Bergman & Norlander, 2005).

2.5.4 Results

During the course of the study four themes emerged, each consisting of several categories: (a) the therapeutic work model, (b) the transformation of feelings, (c) self-insight and (d) meaning. The four themes reoccurred on a regular basis throughout the study and constitute what was termed as “the therapeutic circle”. The therapeutic circle was given new nourishment during the eight therapy sessions, which the clients experienced provided additional meaning and understanding. This, in turn, also contributed to deepening the effect of all the occasions when the clients visited the flotation tank on their own, as indicated in the journals. Each time they visited the flotation tank, i.e. every two weeks, they experienced that the therapeutic process gained new momentum and that, on their own, they could make use of and develop the tools they had received from the therapists. It was thus that a “therapeutic spiral” arose, where each revolution generates more meaning and more wellbeing.

A follow-up 18 months after the completion of the therapy revealed that the spiral of increased meaningfulness and enhanced wellbeing was still in operation. The clients were no longer on sick leave and had jobs that they found meaningful. Since their self-insight had grown, it was easier for them to maintain a good balance and distance when problems occurred. Their daily anxiety had ceased, temperature changes in their bodies were less frequent and their various aches and pains had disappeared or had been dramatically reduced at the same time as they had stopped taking medication.

3. GENERAL DISCUSSION

3.1 Introduction

Only a few studies have been conducted in which treatment programs with the flotation-REST of longer duration were examined. There are even fewer studies assessing long-term effects. Thus, the empirical database is small, and additional studies need to be performed before firm conclusions can be drawn regarding the mechanisms involved in the treatment through the flotation-REST technique. However, it is already possible to ask some relevant questions in connection with the theoretical perspectives reviewed in the current thesis

3.2 How do the results pertain to Melzack's perspective?

3.2.1 Non-linear thinking about pain perception

The neuromatrix theory (Melzack, 1999) views pain as a multi-dimensional experience (the neurosignature) produced by the neural network of the neuromatrix. It is activated by sensory input, but independently it also generates sensations and experiences of pain. Thus, it becomes important to explore if the signature can be affected during a relatively brief period, and if such a potential change can remain over time. In order to achieve this goal, it is important to consider a series of variables included in the matrix. Stress-related symptoms have been examined uni-factorially for a long time (Levi, 2002). Currently, stress-related symptoms are explored in a multi-factorial manner, although linear relations are assumed, simultaneously (Levi, 2002).

The above reasoning constitutes a problem. Levi (2002) argued that one ought to examine the variables in a non-linear, interactionistic, and systems-analytic manner, as well. From this perspective, the neuromatrix fits in well, as does the flotation-REST method. As mentioned earlier, a cognitive change typically takes place in the individual lying in the flotation tank, in which secondary processes (logical or linear thinking) give way to primary processes (intuitive and non-linear thinking) (Norlander et al, 1998). In this way cognition is created which is reminiscent of the interactive character of the neuromatrix. The results from Paper IV support this line of reasoning. Below, the dependent variables of the current thesis will be discussed in relation to Melzack's perspective.

3.2.2 Pain measured by the Pain Area Inventory

The experience of pain is affected by many components, and it is multi-dimensional (Flor, 2000; Skevington, 1995). It is of course an obvious variable in connection with studies of the neuromatrix. The experience of pain is complex and affects several different domains of an individual's life (Crombie, Croft, Linton, Le Resche & von Korff, 1999). It affects our thoughts, emotions, previous experiences, and personality characteristics. Given that the pain theory integrates various dimensions of the neurosignature, a combination of variables is needed in order to describe the composite experience of pain. One such dependent variable used here is the distribution of different areas of pain over the body. The pain measure, the PAI, was used to measure the range of the pain with one single, composite instrument. The instrument was validated by comparing it to various pain measures: the total number of pain types, the number of adjacent pain areas, the worst imaginable pain, typical pain intensity, and frequency of pain experiences (Paper II).

The results from Paper I indicated that the treatment significantly reduced the distribution of the pain by 48 %, and the effect remained four months later at a follow-up assessment. The results from Paper II showed a reduction by 68 % on the basis of the PAI. Finally the results from Paper III indicated a reduction by 56 % in regard to PAI. One could interpret these results to indicate that the experience of pain had undergone a change, affected the perception of pain, such that a different neurosignature developed. According to the neuromatrix, one could argue that this process occurred through an effect on the pain perception dimension and probably also in the action programs resulting in a change of behavior. In addition, the matrix theory implies that changes in one part of the system have repercussions in the entire system. This notion holds for the peripheral parts of the nervous system as well, where transmission of pain is also present, suggesting that at that level there is no conflict between the neuromatrix theory and the gate control theory (Linton, 2005).

3.2.3 Stress and Energy measured by the Stress and Energy Test

Psychosocial factors and stress can elicit disturbances of bodily functions (Levi, 2002) and pain as well. Pain negatively affects the regulatory systems of the brain and the body. Via complex hormonal and neural programs, processes are initiated in order to restore the balance of the biological systems and the psychological functions. Strain and imbalance in the various systems entail damage, degeneration, and stress-related behaviors such as smoking of tobacco,

and the use of alcohol. In both studies, the SE-test was used to assess the perceived degree of stress of the individuals. In Paper I the treatment reduced the level of perceived stress by 31.4 % and the results remained four months later, in Paper II the level of stress was reduced by 39 %, and in Paper III the level of stress was reduced by 25 %. A possible interpretation of these results might be that several dimensions of the neuromatrix were affected with lasting effects: the Stress-Regulation, Cognitive-Evaluative, Motivational-Affective, Pain Perception (including the feeling of stress”) dimensions.

The results from Paper I did not show any significant changes in energy level. In Paper II there were also no treatment effects in terms of energy level, although those individuals who received a higher degree of attention displayed a higher level of energy both before and after treatment, and those who did not have the burn-out diagnosis generally displayed a higher level of energy than those who had the burn-out diagnosis. In Paper III the patients with no burn-out diagnosis also displayed a higher level of energy than those who had the burn-out diagnosis but similarly there were no flotation-REST effects. Energy is associated with activity (Kjellberg & Iwanowski, 1989). During flotation treatment all activity is drastically reduced, and even between treatments patients typically view themselves as “slowed down”. This notion might explain why there were no observed significant changes in energy level. It would be interesting to examine their level of energy four months after the flotation-REST treatment, something that was not done due to the design of Paper I. The conclusion is, then, that the neuromatrix was not affected in terms of energy level during the treatment itself. Relaxation treatment has an energy-saving (Setterlind, 1990) and anabolic function (Lundberg, 2002). The concept of energy, itself, is related to the neuromatrix in several dimensions such as the Motivational-Affective dimension and in the Stress-Regulation programs, which regulate the anabolic and metabolic functions of the body.

3.2.4 Anxiety and Depression measured by the Hospital Anxiety Depression Scale

The individual’s feelings of anxiety and depression were measured on the HAD scale. The results from Paper I indicated that anxiety diminished by 27.4 % following treatment and that the effect persisted four months later. In Paper II anxiety was reduced by 32.6 % and in Paper III anxiety was reduced by 26%. An interpretation might be that the Cognitive-Evaluative part of the neuromatrix was affected.

The results from Paper I indicated that depression diminished by 24.1 % and that the effect persisted four months following treatment. Those who had not been given the diagnosis of burn-out displayed a reduction of depression, but after four months the original level returned. Those who were diagnosed with burn-out also showed a lowered level of depression, and in their case the effects remained four months later. In Paper II depression also diminished following treatment, by 40.2 % and in Paper III depression diminished by 32%. A further analysis showed that there was no significant difference in the non-depressed group but there was a significant effect in the depressed group. The results were interpreted to indicate that the Cognitive-Evaluative part of the neuromatrix had been affected more long-term in individuals with a burn-out diagnosis.

3.2.5 Optimism measured by the Life Orientation Test

The results from Paper I showed that optimism increased by 8.3 % following treatment and that the effect was maintained four months later. The results from Paper II indicated that optimism increased by 9.4 % and in Paper III the optimism increased by 10%. In Paper II it was also shown that those who received a higher degree of attention increased their optimism less than did those who received normal attention, a result that is difficult to interpret. Optimism can be anchored in the Cognitive-Evaluative part of the neuromatrix.

3.2.6 Positive and Negative Affectivity measured by the PANAS

The results of Paper I indicated that neither positive nor negative affectivity were affected by the flotation-REST treatment, whereas the results of Paper II showed that positive affectivity increased by 9.7 % and negative affectivity decreased by 15.3 %. In Paper III the negative affectivity decreased by 11 % and further analysis indicated significant flotation effects only for the group with burn-out depression. The concept of affectivity is represented in the matrix under the Motivational-Affective and the Cognitive-Evaluative dimensions.

3.2.7 Quality of Sleep measured by a VAS-scale

The results from Paper I showed that the quality of sleep increased following the treatment by 23 % and that the effect remained four months later, whereas the quality of sleep was not affected as reported in Paper II. Patients who did not have a burn-out diagnosis showed an increase in sleep quality immediately following treatment, but at four months follow-up the level was back to base

line. The patients who did have the diagnosis of burn-out displayed an improved quality of sleep following treatment, and a trend analysis showed that the level continued to improve even four months later. In Paper III the sleep quality increased by 18%. Quality of sleep is strongly associated with depression, pain, quality of life, and insomnia (Ballard, 1993; Dean, Lee, David & Lauren, 1998; Marin, Cyhan, Miklos, 2006; Wilson, Eriksson, D'Eon, Mikail & Emery, 2002; Smith, Perlis & Haythornthwaite 2004). The complexity of the experience of sleep should be interpreted in a systems analytic manner. In accordance with the neuromatrix, aspects of sleep are seen as an interaction among several areas of the brain and its neural structure (Melzack, 2005). Motivational-Affective, Cognitive-Evaluative, Pain Perception and depressive aspects of the Cognitive- Evaluative dimension generate a composite, qualitative experience of sleep during wakefulness. Sleep is affected in different ways throughout the neuromatrix as well as peripherally in the body via the stress-regulatory systems.

3.2.8 Blood pressure measured by a sphygmomanometer

Systolic and diastolic blood pressures was measured in the three experimental studies, and in Paper II diastolic blood pressure decreased by 3.9 % following treatment, but no significant effects were found in the data from Paper I. In Paper III the diastolic blood pressure diminished only after 33 treatment sessions. Blood pressure is also placed within the frame of Stress-Regulatory systems where it constitutes a type of marker for the balance between sympathetic and parasympathetic activity (Setterlind, 1990).

3.2.9 Cortisol and prolactin measured by blood assays

The results from Paper I showed that the level of prolactin increased by 33 % immediately following treatment and decreased to base level four months later at the follow-up. One speculation might be that prolactin increases the level of vitality. Earlier studies have shown that an increased level of prolactin is initiated during sleep and that it has a healing effect on wounds (Lindholm, 1996). An increased level of prolactin over a prolonged period of time is deleterious to the organism (Werner, Bengtsson, Petrus, Karlsson, Bolander, Brammert, Valdemarsson, Bynke, Öhman, Olsson, Rasmuson & Änggård, 1999). As of now, it is not exactly known how prolactin works in the body. One speculation has been that prolactin may function as “ignition” vis-à-vis other hormones (Adkins-Regan, 2005), but it has been demonstrated that it is released during the care of a child, and that it elicits a desire to care for and

protect children (Grattan, Pi, Andrews, Augustine, Kokay, Summer, Todd, & Bunn, 2001; Lundberg, 2002). The release of prolactin affects the neuromatrix through the Stress-Regulation Programs, Action Program, and the Motivational-affective dimension. Another stress-related marker, cortisol, was also examined. Due to the use of not quite reliable routines for blood assays, the measurement of cortisol was probably affected, compromising a correct analysis of the cortisol. Due to financial restrictions, blood assays could not be performed in Paper II or Paper III.

3.3 Do non burn-out and burn-out patients have different neurosignatures?

Twenty years ago, the American psychologist Christina Maslach coined the concept of burn-out (Maslach, 1982). According to Maslach burn-out is caused by chronic stress. It is characterized by physical and emotional exhaustion leading to cognitive disturbances, cynicism with regard to work and people, including hostile and negative attitudes. Burn-out is a type of depression characterized by a lack of efficiency and a negative view of one's own work output, as well as psychological and physical ill-health (Lundberg & Wentz, 2005). The neurosignature for the burn-out patient is characterized by chronic fatigue, sleep disturbances, depressed mood including a sense of hopelessness and depression, easily triggered aggressiveness, wining, intolerance, muscular pain, aches in the tendons, and in the head, a lowered immune defense, numerous infections, inexplicable states of poor health as well as disturbances of concentration and loss of memory (Lundberg & Wentz, 2005). The neurosignature for a patient with stress-related pain but no burn-out is characterized somewhat less by negative affectivity and somewhat more by energy, optimism, positive affectivity, all in line with Papers I, II, and III. In all those papers, as expected, the patients with the diagnosis of burn-out depression exhibited significantly higher values on depression as compared with patients without such a diagnosis. Subsequently it was the depressed patients who gained most in regard to depression.

The signatures of the two individuals thus look different despite the fact that both individuals suffer from stress and pain. There are, however, strong associations between them. As mentioned earlier, chronic stress affects the different areas of the neuromatrix and triggers stress-related symptoms such as pain. When stress and pain are left untreated, the problems worsen and the risk of burn-out depression becomes evident (Lundberg & Wentz, 2005). The empirical expressions can be attached to the complex, neural network of the

neuromatrix and provide an increased understanding of the development of stress-related symptoms as well as pain.

3.4 Why does flotation-REST affect the neurosignature?

3.4.1 Relaxation is an appropriate therapeutic instrument

Tension is a central construct within research on relaxation. Since tension can be both psychological and physical, our well-being is affected (Papers I, II, III, and IV). Physical tension is felt through diffuse feelings of restlessness, anxiety, irritability, and impatience (Setterlind, 1990) including disturbances of psychological harmony, affecting the neurosignature and the body (Paper IV). The jaws, shoulders, neck, back, and stomach become tense (Setterlind, 1990). The basic tension then becomes abnormal tension and abnormally tensed muscles, when we are exposed to intense demands and strain. It is an issue of demands and strain resulting in different forms of stress reactions, which, in turn affect the Stress-regulation programs and generate stress-related disorders (Ekman & Arnetz, 2002). The combined effect of psychosocial and psychobiological stimuli determines the expression of psychological and physiological reactions in the neurosignature, unique for each individual (Melzack, 2005). It has been shown that relaxation is an appropriate and relevant therapeutic instrument for the prevention of a series of stress-related disorders and illness processes, all of which are related to neuronal changes in the neurosignature (Esch et al, 2003).

3.4.2 Eliciting the relaxation response in highly stressed people

In order for a relaxation technique successfully to elicit a deep type of relaxation (RR), two factors are necessary, according to Ben-Menachem (1977), namely reduced sensory input, and reduced bodily movement. Deep relaxation with reduced body movement and reduced sensory input opens the door to the relaxation response (Esch, et al 2003). As mentioned above, the problem is that if a person is wound up, it is difficult to stay bodily and psychologically calm, making it difficult to use traditional relaxation techniques with those individuals who need them the most. It was shown early on (Goldberger 1961; Noy, 1967) that sensory deprivation results in cognition dominated by primary processing by way of reduced feedback to the secondary processing. The flotation-REST technique, which is based on sensory deprivation, has been shown to produce a strengthened state of primary processing (Norlander, 1997; Norlander, et al 1998) and shown that the state is perceived as relaxing (Norlander, Bergman &

Archer, 1999; Sandlund, Linnarud & Norlander, 2001). At the same time patients find it easy to rest calmly in the warm salt water without any disturbance. All in all, the results indicate that Ben-Menachem's two requirements for the elicitation of an RR (i.e. reduced sensory input and a reduction of body movements) are met, even in an individual with bodily tension and anxiety

In a number of ways it can be demonstrated that the flotation-REST indeed elicits the RR, even in individuals with severe stress symptoms. According to their scores on the test instrument, Experience Deviation from a Normal State (EDN), the patients achieved an altered state of consciousness, as early as after the first flotation visit, and the state intensifies after an additional 11 flotation sessions (Paper I). In addition, earlier observations indicated that patients spontaneously reduced their intake of medicines and alcohol, and these facts may suggest that the RR was elicited on a regular basis over a period of time (Paper II). It is possible to speculate that when the RR is elicited in an individual with severe stress symptoms, the stress response is inhibited, allowing the natural force of the body towards recovery to become activated. This process allows for changes in the neurosignature, resulting in a reduction of the experience of pain (Papers I, II, III, and IV), in a reduction of the feelings of stress, anxiety, and depression (Papers I, II, III, and IV), in an increase in optimism (Papers I, II, III, and IV), and in positive affectivity (Paper II).

3.4.3 Creativity

Bergström's more biological perspective (1992) is relevant to the observations above. In his model, chaotic signals travel from the primitive brain stem to the more highly developed cortex. At the same time, the cortex transmits ordered signals downward in the brain. The flows of signals meet in an interactive field containing among other structures, the limbic system (MacLean, 1973). In the meeting of these signals, a third dimension is formed, the neuropsychological self, a self with a real dimension reflecting the sensory input from the physical environment of the individual and an imaginary dimension reflecting the input of signals from the chaotic brain stem, the internal feelings and need-based assessments (Lagerroth, 2006). The real dimension represents what we "know" about our physical environment whereas the imaginary dimension represents what we "feel", our internal existence (Bergström, 1992). Bergström argued that Man's self is the result of the forces of the conscious and the unconscious, of order and chaos. A balanced self requires well-developed imaginary and real

processes (Bergström, 1992). The tension between the two basic functions provides a creative transformation and interpretation of the different expressions. Through deep relaxation with a reduction of body movements and sensory input shifts between order and chaos, primary and secondary processes can be maintained and be further refined to new individual observations. Bergström labeled them the "dissipative structures" (Bergström, 1992; Lagerroth, 2006). Here, novel progress and creativity are shaped through competitive dynamics (i.e. dynamics which follow principles completely different from the logical and the purely chaotic laws of Nature).

Bergström (1983) believed that new thoughts and ideas emerge like "damage from a collision" between the signals from the brain stem and the cortex, and that it is important to find ways to become conscious of them before the secondary process removes them because of being too logical. In order to come into contact with more intuitive levels, Bergström recommended "open air, love, enthusiasm, friendship" (Bergström, 1983, p. 148) as a way of reducing the dominance of secondary processing over thinking, thereby releasing creativity. Previous studies have shown that the flotation-REST technique has favorable effects on creativity (e.g., Norlander et al., 1998), and it is possible that Bergström's hypothesis may shed light on this phenomenon. This aspect is also important to patients with severe pain problems. An increased, creative experience might provide new impulses with regard to moving forward in life, and might positively affect the neuropsychological self, here viewed as a direct counterpart of the neurosignature.

3.4.4 Meaning

Bergström (1992) argued that it is indeed possible to gain a good idea of the resources of the human brain, given our current knowledge. In general, the brain contains three types of resources, namely "power" (the physical and mental intensity expressed through our will power), "knowledge" (order and information), and "value" (the ability to choose and sample, thereby producing meaning). The three types interact in specific ways when we use them to survive. There are centers in the brain stem which activate consciousness as well as the muscular system (Bergström, 1992). The brain stem possesses the basic resource for our behavior, the force which during physical activity is expressed as the physical energy of the muscles, and during mental activity as mental intensity. It is expressed as an integrative aspect of the whole for the reticular activating system of the brain stem, which in turn- by way of diffuse streams of signals- connects the streams of signals of the brain stem with the

sensory patterns of the cortex into a whole, a kind of mental macro state (Bergström, 1992, p. 40). Sperry (1973) also showed that the brain has the ability to view the environment in a holistic way, particularly the right hemisphere, through a synthetic and “pictorial”, intuitive process.

Bergström argued “if we look more closely at the holistic resource of the brain, we realize that it was intended to make selections and appraise information” (Bergström, 1992, p. 42). The ability entails the condition of combining and comparing structures of knowledge, i.e. to view them together as a whole. For this reason Bergström called this third resource, ability to assess knowledge, a value capacity. With the aid of the value capacity, we choose the knowledge best suited to a given situation, and with the aid of the knowledge we steer the force in space and time, in accordance with our demands and needs and those of the environment. Man’s notion of the world is constructed out of the three resources, force, knowledge, and value (Bergström, 1992). The concept of value is central to studies of human social development. In Paper IV a model of development with four main themes was described, i. e., the therapeutic model which contributes to a transformation of emotions, thereby leading to enhanced self-awareness and experiences of increased significance and meaning of life. With the deeper understanding new perspectives may enrich the model. The development is seen as the result of a combination of therapy and the effects of the sensory deprivation in the flotation tank.

Knowledge obtained from several religions (Geels & Wikström, 2006) has taught us how wise men and women retreat to solitary places, where sensory impressions diminish, in order to start out on an inner voyage. In his doctoral dissertation on the psychology of meditation, the Dutch psychologist, van der Lans, argued that included in all kinds of meditation are bodily relaxation and an immobile posture as well as a significant reduction of the normal flow of stimuli (Geels & Wikström, 2006). In the Judeo-Christian tradition there are many examples of prophets who venture out into the stimulus-barren desert, as shown in several citations from the Bible along the theme of “the god of Israel is the god of the desert” (e. g., Hos 2: 14, 2: 19-20). In his dissertation, which primarily deals with altered states of consciousness in the flotation tank, Kjellgren (2003) suggested that the method of sensory deprivation appears to elicit existential thoughts in the patients: that an increased sense of meaningfulness and even spirituality has therapeutic potential. This idea has been shown in several studies (c. f. Snyder & Lopez, 2002).

3.4.5 Relative weightlessness

In order for the "I" of the brain and the sensory system to work, the primitive brain stem must develop (Bergström, 1992). The primitive reflexes and the primitive motor system develop early during gestation and later during the first phases of childhood. The motor system develops when the child learns how to counteract gravity in his first movements. Given that the young child existed in relative weightlessness in the uterine environment, it is possible that the child possesses an unconscious wish to return to that state, later during development (Bergström, 2006). During play the child shows how he "loves" weightlessness, the highest point of swinging, the motion of falling, and swimming in water. If the early, primitive functions fail to develop, later functions of the ego fail to develop as well. Bergström (1992) suggested that a balanced ego requires imaginary and real processes to develop fully in the brain. Bergström argued that consciousness and a spiritual ability are but one form of gravity. The reason is that the muscles counteracting this force (the anti-gravity reflex) are a necessary source for the neural development of the brain stem, and later the development of higher conscious functions, such as the development of the value function and the spiritual ability. The activity of the muscles and the mental intensity are governed by the same nerve centers at the back of the brain stem. Thus, "both the physical and mental forces in principle constitute the same energy, only in different forms" (Bergström, 1992, p. 48).

There exists a theory that says that by exercising the primitive, sensori-motor functions and reflexes, one can remedy disturbances of the higher cognitive functions (Niklasson, 2001; 2005). A daring speculation might be that occasional but recurrent experiences of weightlessness could open the possibility for contact with the vestibular mechanisms, early, basic patterns of reflexes at the sub-cortical levels. This notion might then make possible a re-organization of the early patterns of reflexes along with motor behaviors learned later, and a coupling of the anti-gravitational reflexes with sensori-motor and fine-motor patterns of movement. During weightlessness the primitive reflexes may be re-experienced and readjusted through changes in posture and the sensations thereof. If this were the case, energy might be released, since energy is needed in order to maintain a static posture, whether conscious or not. Energy is released when tension ceases. One gains surplus energy for other activities such as cognitive and mental processes and an increased ability to reorganize thoughts, eg. re-focusing attention. At the Human Performance laboratory we have made observations, which could

support such a speculation, namely the fact that patients sometimes report experiences of involuntary sensations and twitches of the body.

3.5 Can the mending of the neurosignature be illustrated?

3.5.1 Introduction

In Paper IV, flotation-REST in combination with therapy was investigated. The analysis yielded 238 meaning units, which generated 12 categories. Each category illustrates a special perspective of the phenomena studied. The categories are presented below in the random order they had during the analysis. These categories can contribute to the illumination not only of the combination of the flotation tank and therapy but also of experiences typical of the flotation tank therapy itself. The clients kept diaries concerning their experiences from all of their approximately 35 flotation sessions, eight of which took place immediately following the conversational and pictorial therapy. Through these types of therapy the clients were able to reflect on and put words to their experiences from the flotation. The descriptions below are examples of comments by the clients, obtained from the original Results section of Paper IV (Åsenlöf, Olsson, Bood & Norlander, in press), subsequently removed during the review process due to lack of space.

3.5.2 Cognitive strategies

Sorting and processing thoughts increase the opportunity to break engrained thought patterns and create a better balance between feeling and reason. Maintaining a distance increases control over thoughts and feelings and provides an understanding of what they mean and their consequences for practical actions. The clients' responsibility for their lives becomes clearer and changing their life situation becomes their own active choice. Thoughts, feelings and bodily reactions are consciously influenced through their will and this facilitates the development of positive images of the future.

Example: have so many thoughts that I want to sort out/I need these 45 minutes, now I think things are moving too fast for me to be able to sort out my thoughts and I go through the conversation/ I try to see my feelings, what they do to me, what I can do, what use I have of feeling this way.

3.5.3 Feelings

Feelings have become more apparent during therapy. There are negative and positive sides to every feeling. By stepping in and out of the feeling the clients

can also control the feeling (identify/deidentify). Oppressive and difficult feelings have previously dominated and prevented happiness from emerging. A better balance and an enhanced awareness have appeared. Feelings that they are really not proud of and want to remove have nevertheless been of assistance in certain situations. It is therefore not a good idea to get rid of them. It is possible, instead, to make use the different sides of the feelings. Flotation has also allowed feelings to emerge that cannot be identified. This has produced pain in the throat and chest.

Example: it's as if the cup is overfull so the smallest extra drop causes it to overflow, the glass should be a little deeper, more balance, yes, looking back, I think things have changed a lot, so there is a very great difference/what I have learned most here about feelings is, I think, to bring out the feeling and study it, when we went into different feelings and indicated plus or minus, what positive effects do I have from feeling like this and what negative ones, and discovered that even those feelings that I did not want to have, that I wanted to get rid of helped me in certain situations and that it was not wrong to feel like that/ but I have realized now that it is so, I look at my feelings completely differently and see what is good and bad and can use what I previously thought was negative.

3.5.4 Self-Insight/Self Esteem/Self Confidence/Self Image

The increased inner awareness, self-insight, makes it easier re-evaluate old life patterns and expectations. Demands from the outside and efforts that often lead to feelings of insufficiency and of not being good enough have been reduced in scope and replaced by greater independence and freedom. It is easier for the clients to listen to themselves, to see who they are and to dare to show it. Self-reliance and trust in others grows. By accepting and understanding themselves and their needs, it becomes easier for them to relate to their surroundings. Anxiety, fear and worry are reduced and replaced by inner satisfaction and harmony.

Example: learned to listen more to myself/ I think it is these positive periods, I can go out, meet and be with people, rely on myself if we agree on something/ this is what is most important, with demands and being capable, let it go, you're all right anyway, without being capable and having to something

3.5.5 Inner Strength and Courage

The thought process that the therapy and flotation started has developed the clients' inner strength and courage, which means they are able to think more freely, put forward their own ideas and takes responsibility for them. They dare to talk about what has been difficult and bring forward what is genuine within them and reveal it to others. They are allowed to make fools of themselves, let everything go without being afraid. Inner strength and courage have grown stronger as the treatment has progressed.

Example: I feel that this has started a thought process in me that I am afraid of losing as I still have a very long way to go, a little more courageous thinking and a little tougher/ I have gained more courage to assert my own ideas / icy feeling, there is still a little left of the old me but my body doesn't feel as bad when I come up, I have gained strength there, a lot from the floating but even from the therapy

3.5.6 Presence, Concentration and Focus

An inner peace and greater presence have developed during the treatment. Because the clients feel more harmonious, they can think more clearly and more easily receive signals. Being able to focus better and talk to themselves means that they can discover other things and have the chance of developing new values and other ways of thinking. The ability to concentrate increases in the flotation tank and through a conscious action of the will disharmonious thoughts can be collected and sorted.

Example: it is less than it was in the beginning, much more peaceful, quite a big difference with much more calm, not as confused I would say/ Thoughts are clearly more collected in the flotation tank/ naturally sad thoughts occur now and then but I can deal with them as it were, handle them differently so they don't remain in the body, I can put them down as it were

3.5.7 Fear

The various fears become more distinct during the therapy. Change and personal development force fear and anxiety to the surface. Fear is an obstacle to seeing new opportunities in life. Allowing fear to emerge during therapy gives a person the courage to face their subconscious and make the necessary choices irrespective of the consequences. During the treatment the attitude to "fear" changes. Mistrust and fear increasingly become trust and confidence. No fear arises in the body during flotation but this is the case during therapy.

Example: I don't know why I am so afraid, you aroused it especially when we interpreted the paintings, you elicited thoughts which make me afraid, more afraid that I shall do something difficult which will allow me to break free of all the "musts" and that this will cause someone to suffer who means a lot to me/ it is a feeling of anxiety whose origin I can't trace, many thoughts about what it is can arise at the same time as I see the chance of finding it, it must be that I am scared otherwise I wouldn't feel anxiety, it is difficult, obviously I want to run from it/ she was open (the other client) and I was more reserved and became afraid instead but I think I have changed a lot, I think I was afraid in the beginning, I was afraid of people

3.5.8 Anger and Frustration

Anger helps the clients break engrained patterns, to take hold of themselves and move forward. Anger grows stronger as the insight that they are responsible for their own lives becomes clearer. When anger is not cleansed from the body, it turns into anxiety and this leads to sorrow and grief. It is frustrating not to be able to find words to describe different feelings. It is difficult to decide what is right and wrong.

Example: anger, I lie in the flotation tank and wonder if I can shout, if they will hear me then, sometimes you wish there was a sound-proof room where you could go in and shout/ it feels as if you have a balloon in your throat and you pump and pump and pump and finally you think it'll explode, you see, it feels as if there was no room, it explodes/ it is very frustrating trying to find the right words

3.5.9 Aches and Pains

Training to relax in the tank and guided meditation has resulted in the reduction and gradual disappearance of neck pains and headaches. The burning sensation under the soles of the feet and the smarting sensation on the skin has also disappeared. The inner mental pain was also influenced positively during the relaxation treatment. In general it may be said that increased bodily awareness has led to greater control over the pain, which gradually disappears.

Example: I train breathing relaxation when I lie in the tank, my problem or pain is in my neck and head, I have virtually chronic tension headaches, my neck is stiff and no, but I think it has got better/ I feel good in my mind, there's no pain, no physical pain at least/ sometimes I feel I can float my headache away, not always but sometimes I think so, if only I can relax.

3.5.10 Benefits from Illness

Illness has made inner personal development possible. It has led to new insights and positive experiences. It has created better relations with relative and friends and has also resulted in greater respect and understanding for other people. The basic attitude in the clients is that the illness has developed to enable them to make changes in their lives. The inner shame at being ill has disappeared during the treatment.

Example: and then I began to understand since I saw it as something very shameful, now I feel privileged and I am so awfully happy that I can be part of this, so a lot has happened since I became ill/ I have searched all the time since I became ill, I have searched for a meaning, I believe there is some meaning in what happens/ if I had not become ill, I wouldn't have experienced this, I mean these pearls

3.5.11 Floating

The flotation tank provides the clients with an opportunity to sort through the therapeutic conversations and clear their brain from confusion and chaos. It is a space where they can analyse thoughts and feelings, a place where they say they feel good and where they dare to be themselves, relax and enjoy the freedom. Floating has also resulted in considerable bodily awareness, which in its turn has led to a greater acceptance of themselves and their own body. Focusing on and consciously following the path of breathing through the body has led to a deeper bodily awareness and contact with themselves, which entails a release from tension, anxiety and pain. Relying on the salty water creates a sense of security and an inner peace. Nowhere is this more obvious than in the tank. What happens in the tank is beneficial and healing. The tank gives them time to think and work through the therapeutic conversation. It is a solitude that does not lead to anxiety and anguish but brings peace and harmony. Nothing or nobody can disturb one. It is dark and quiet. Time no longer exists in this weightless condition. There is time to determine what is going to happen, time to make important decisions. Time to encounter oneself.

Example: when we float after the conversation we have 45 minutes when it is quiet and you can go back and sort out your thoughts, I have learnt to listen to myself/ floating is perfect for the weightlessness and the warmth make you feel good/ what has happened since I started floating until now is that I don't get pains in the neck anymore, I have learned to relax my body.

3.5.12 Spirituality and the Superego

“Spirituality”, or the “super conscious”, clearly emerges during the flotation. An inner room has been created where it is possible to evoke positive memories, enter into them and enjoy them. Images and symbols also emerge there which show what thoughts and feelings look like. Dark colours are changed into lighter ones. Similarly, smells and scents are perceived. At the end of the flotation period, repeated string music is heard, guitar and piano, sometimes only in the form of individual tones. In contact with the light, love and happiness in the universe, trust and belief in the future become stronger. Fear and strife disappear. Body and soul are integrated. A mental and spiritual dimension emerges and a new "transpersonal" vision enables the clients to find the core of their being and thereby make contact with the superego, “the self”.

Example: I can take some deep breaths and relax and capture this universe’s light, love and happiness, fill my body with what is positive/ what you perhaps use consciously is a form of intuition, I can almost feel the energy directly, how it vibrates, how I hold the energy in my hands/ I see solitude again whether it is my own or a shack where I can go into myself and experience even stronger feelings in the face of my soul and dare to believe that this is not just imagination but that there is something to trust in, so you let go of fear

3.5.13 Conversation-Floating-Painting

The combination of conversational therapy, floating and painting has been effective. It enables the process to grow without being talked to pieces. The therapeutic conversation often results in mental chaos. Therefore, instead of being sent out alone, the clients are given time in the flotation tank to deal with and sort out their thoughts and feelings. Flotation helps to produce positive images of what was difficult in the therapy. Flotation has a different meaning when it is linked to therapy. It is given a higher priority. The value and significance of conversational therapy become clearer. These insights remain with the clients and can be processed later at home. The paintings show what has happened in the flotation tank and also clarify the thoughts and feelings examined during the therapy. The therapeutic model consisting of three sections is perceived in such a positive manner that it should be offered to more clients. The model binds together thought, feeling, body and soul. The journals have been a tool for documenting and understanding what has taken place during the therapy sessions. The three different forms of treatment are put on paper and can be reread later as a reminder.

Example: it has been beneficial to have both the conversational therapy and the flotation because I think they belong together/ there are many like me who find conversational therapy difficult and who would like to have this time to sort out their thoughts/ the model for the project has been very good, being able to paint, I think, has been wonderful for the thoughts that come during the flotation can move into calmer music when you come out of the tank.

3.6 Are there differences between women and men?

Our clinical experience from the current dissertation is that most of the clients were women. It has been argued that significantly more women than men seek help from the medical community for stress and stress-related problems (Lundberg & Wentz, 2004). It is also true of those who seek help from, or are referred by a physician, to the Human Performance laboratory. For this reason it comes as no surprise that 77.6 % of the participants in the current dissertation were women. The small number of men precluded gender comparisons in the studies above. However, the men were assigned to the various conditions in a randomized way.

Now that the entire material collected can be scrutinized, it is possible to conduct statistical gender comparisons on the participants of the three experimental studies, which consisted of 95 women (77.2 %) and 28 men (22.8 %). Analyses were conducted using three-way split-plot ANOVAs with Gender and Group (control, flotation) as between-subjects factors and with all variables used before and after treatment as within-subjects factors. Of all these analyses, only three significant effects were found for gender: the upper threshold value measured with the Pain Matcher, pain frequency, and alcoholic consumption. With regard to the upper threshold value (i.e. the ability to endure pain) it was found that men were better able to do so ($M = 74.21$, $SD = 32.15$) compared to women ($M = 32.96$, $SD = 24.62$). With regard to pain frequency (i.e. how frequently they felt pain), men felt pain somewhat more frequently ($M = 4.08$, $SD = 0.80$) compared to women ($M = 3.64$, $SD = 1.12$). Finally, the men exhibited a higher monthly alcohol consumption, assessed as ml 100 % alcohol ($M = 304.32$, $SD = 179.82$) compared to the women ($M = 192.86$, $SD = 308.01$).

It was our expectation that men would have a higher pain threshold, a finding in line with earlier observations (Josefsson, Karadaghi, Klinge, Louca, Pourjanaki & Svård, 2003). There have been discussions whether the observed difference between men and women represents a physiological aspect of pain

or whether it is a psychological effect of how pain is reported (Gracely, 2006). The results from the three studies in the present thesis speak against the idea that there is a difference of reporting since the assessment entailed how persistently the clients could hold on to an instrument producing increasing pain. Also in line with previous research is the finding of a higher consumption of alcohol among men (Norlander, 1997; Norlander, 1998), but there is no apparent explanation why men felt pain somewhat more frequently than women. With the exception of the above three findings, there were no gender differences either in the control group or in the flotation groups. The conclusion is thus that there were no significant gender differences among the participants of the current studies who had the diagnosis of stress-related pain, with or without burnout depression.

4. CONCLUSIONS

The overarching purpose of the current thesis was to assess the long term effects of a documented treatment program involving flotation-REST for the experience of pain, from the point of view of variables connected with Melzack's neuromatrix theory, and to examine the extent of a potential attention-placebo effect in connection with flotation-REST. An additional purpose was to explore whether neuromatrix theory constitutes a functional frame for an understanding of the empirical results of the current studies.

The results from the three experiments (Paper I, Paper II and Paper III) are in agreement with those of earlier studies regarding the ability of the flotation-REST technique to reduce stress, as shown in a recent meta-analysis (van Dierendonck & te Nijenhuis, 2005). Furthermore, the results support those of earlier studies of the ability of the flotation-REST method to alleviate pain (Kjellgren et al., 2001). A previous study (Norlander, Kjellgren & Archer, 2001) showed that the flotation-REST method is not particularly affected by an expectancy-placebo, and the results of Paper II showed that this notion is also true of an attention-placebo. Taken together, Papers I, II, III and IV have contributed the following to the flotation tank research: (1) The patients were treated for longer periods of time than they were in previous studies, (2) a standardized treatment program was tried out, (3) patients were followed up four months after the end of treatment, (4) a new test of pain was developed, (5) the role of attention was examined directly for the first time, (6) the combination of flotation-REST and therapy was tested for the first time for the duration of a year through case studies, and the effects were compared to a follow-up 18 months later, (7) the work designed to look for biological markers has continued, and prolactin appears to be an interesting possibility, and (8) the variables used have all shown relevance with regard to Melzack's neuromatrix. Given more empirical work and more systematic research, it is time for flotation tank research to become more theoretically anchored. Hopefully, the current thesis will constitute such a first step.

In all papers, the conclusion was drawn that flotation tank therapy is an effective and non-invasive method for the treatment of stress-related pain, and that the method is not affected more by a placebo than by other methods currently used in pain treatment. The treatment of both burn-out depression and pain related to muscle tension constitutes a major challenge for the patient as well as the care provider, an area where great gains can be made if the treatment is effective. An important aspect of such treatment is finding

methods, which involve rest and recovery and an increased ability to experience happiness and hope. Flotation tank therapy may constitute an integral part of such treatment.

5. REFERENCES

- Adkins-Regan, E. (2005). *Hormones and animal social behavior*. Princeton University Press.
- Åkerstedt, T. (2002). Vi behöver sova! [We need to sleep!] *Läkartidningen*, 99, (3),150-152.
- Åkerstedt, T., & Kecklund, G. (2002). Sömn och återhämtning [Sleep and restitution]. In R. Ekman & B. Arnetz (Eds.). *Stress: molekylerna, individen, organisationen och sambället* [Stress: The molecules, the individual, the organization and society] (pp. 264-271). Stockholm: Liber.
- Alstergren, P., & Förström, J. (2003). Acute oral pain intensity and pain threshold assessed by intensity matching to pain induced by electrical stimuli. *Journal of Orofacial Pain*. 17, 151-159.
- Arbetslivsinstitutet, (2006). Valfärd i gröna rum. Hämtad den 6 september, 2006, via <http://www.arbetslivsinstitutet.se/>
- Åsenlöf, K., Olsson, S., Bood, S. Å., & Norlander, T. (in press). Case studies on fibromyalgia and burn-out depression using psychotherapy in combination with flotation-REST: Personality development and increased well-being. *Imagination, Cognition and Personality*.
- Ballard, E. (1993). REST in the treatment of persistent psychophysiological insomnia. In: A. F. Barabasz, M. Barabasz (Eds.). *Clinical and Experimental Restricted Environmental Stimulation*. (pp. 187-203). New York: Springer.
- Ben-Menachem, M. (1977). *Relaxation. A literature survey and an attempt to build a new model. Schoolpsychological therapy research program*. Göteborg, Sweden: Gothenburg School Administration.
- Benson, H. (1975). *The relaxation response*. New York: Morrow.
- Bergman, A., & Norlander, T. (2005). "Hay sacks Anonymous": Living in the shadow of the unidentified. Psychological aspects of physical inactivity from a phenomenological perspective. *The Qualitative Report*, 10, 795-816.

- Bergström, M. (1983). Hjärnan, alkoholen och kreativiteten [Brain, alcohol and creativity]. *Alkoholpolitik*, 4, 142-149.
- Bergström, M. (1992). *Hjärnans resurser*. En bok om idéernas uppkomst [The resources of the brain – a book about the birth of ideas]. Jönköping, Sweden: Brain Books AB.
- Bergström, M. (1995). *Neuropedagogik*. En skola för hela hjärnan [Neuro pedagogic. A school for the brain]. Stockholm: Wahlström & Widstrand.
- Bergström, M. (2006). *Hjärnans neuro-mentala "jag" och dess utveckling under barndomen* [The neuro-mental "I" of the brain and its development during childhood]. Paper presented at the Karlstad seminary on Brain and Brain Functions, Juni, 9, 2006.
- Berkly, K. J. (1997). Sex differences in pain. *Behavioral Brain Science*, 20, 1-10.
- Bood, S. Å., Archer, T., & Norlander, T. (2004). Affective personality in relation to general personality, self-reported stress, coping and optimism. *Individual Differences Research*, 2, 26-37.
- Bood, S. Å., Sundequist, U., Kjellgren, A., Nordström, G., & Norlander, T. (2005). Effects of flotation-REST (Restricted Environmental Stimulation Technique) on stress related muscle pain: What makes the difference in therapy, attention-placebo, or the relaxation response? *Pain Research and Management*, 10, 201-209.
- Bood, S. Å., Sundequist, U., Kjellgren, A., Norlander, T., Nordström, L., Nordenström, K., & Nordström, G. (2006). Eliciting the relaxation response with the help of flotation-REST (Restricted Environmental Stimulation Technique) in patients with stress-related ailments. *International Journal of Stress Management*, 13, 154-175.
- Bood, S. Å., Sundequist, U., Kjellgren, A., Nordström, G., & Norlander, T. (2007). Effects of Flotation REST (Restricted Environmental Stimulation Technique) on Stress Related Muscle Pain: Are 33 flotation sessions more effective as compared to 12 sessions? *Journal of Social Behavior and Personality*, 35, 143-156.

- Brattberg, G., Thorslund, M., & Wikman, A. (1989). The prevalence of pain in a general population. *Pain, 37*, 215-222.
- Cannon, W. B. (1915). *Bodily changes in pain, hunger, fear and rage: An account of recent researches into the function of emotional excitement*. New York: Appleton.
- Cannon, W. B. (1932). *The wisdom of the body*. New York: W. W. Norton.
- Craig, A. D. (2002). How do you feel? Interception: the sense of the physiological condition of the body. *National Review in Neuroscience, 3*, 655-666.
- Craig, A. D. (2003). Pain mechanisms: labeled lines versus convergence in central processing. *Annual Review of Neuroscience, 26*, 1-30.
- Crombie, I. K., Davies, T. O., & Macrae, W. A. (1994). The epidemiology of chronic pain: time for new directions. *Pain, 57*, 1-3.
- Crombie, I. K., Croft, P. R., Linton, S. J., LeResche, L., & von Korff, M. (1999). Pain-related fear is more disabling than pain itself: Evidence on the role of pain-related fear in chronic back pain disability. *Pain, 80*, 329-339.
- Damasio, A. (1988). Emotion in the perspective of an integrated nervous system. *Brain Research Review, 26*, 83-86.
- Dean, A. P., Lee, D. K., David, M. M., & Lauren, B. K. (1998). Pain, fatigue, and sleep in eosinophilia-myalgia syndrome. *The Journal of Neuropsychiatry and Clinical Neurosciences, 10*, 338-342.
- Dickenson, A. H. (2002). Gate Control Theory of pain stands the test of time. *British Journal of Anesthesia, 88*, 755-757.
- van Dierendonck, D., & te Nijenhuis, J. (2005). Flotation Restricted Environmental Stimulation Therapy (REST) as a stress management tool for enhancing well-being and performance: A meta-analysis. *Psychology & Health, 20*, 405-412.
- Dittrich, A. (1998). The standardized psychometric assessment of Altered States of Consciousness (ASCs) in humans. *Pharmacopsychiatry, 31*, 80-84.

- Ekman, R., & Arnetz, B. (2002). *Stress: molekylerna – individen - organisationen – samhället* [Stress: The molecules, the individual, the organisation and society]. Stockholm: Liber.
- Ekman, R., & Lindstedt, G. (2002). Molekyler på liv och död [Life and death for molecules]. In R. Ekman & B. Arnetz (Eds.). *Stress: molekylerna, individen, organisationen och samhället* [Stress: The molecules, the individual, the organization and society] (pp 264-271). Stockholm: Liber.
- Ekstedt, M., & Fagerberg, I. (2005). Lived experiences of the time preceding burnout. *Journal of Advanced Nursing*, 49, 59-67.
- Esch, T., Fricchione, L., & Stefano, G. B. (2003). The therapeutic use of the relaxation response in stress-related diseases. *Medical Science Monitor* 9, 23-34.
- EASHW. (European Agency for Safety and Health at Work) (2006). *Prevent*. Hämtad 6 september, 2006, via: <http://osha.eu.int/about/>
- Fava, G., Perino, G., Santumastaso, P., & Fornasa, C. (1989). Life events and psychological distress in dermatologic disorders: psoriasis, chronic urticaria, and fungal infections. In T. Miller (Ed.). *Stressful Life Events*. Madison, Wis: International Universities Press.
- Fine, T. H., & Turner J. W. (1982). The effect of brief restricted environmental stimulation therapy in the treatment of essential hypertension. *Behavior Research Therapy*, 20, 567-570.
- Fine, P. G., Roberts, W. J., Gillette, R. G., & Child, T. R. (1994). Slowly developing placebo responses confound tests of intravenous phentolmine to determine mechanisms underlying idiopathic chronic low back pain. *Elsevier Science*, 56, 235-242.
- Fletcher, G. (1983). The history of exercise in the practice of medicine. *Journal of the Medical Association of Georgia*, 72, 35-40.
- Flor, H. (2000). The functional organization of the brain in chronic pain. *Progress in Brain Research*, 129, 313-322.

- Folkow, B. (2002). Evolution och fysiologi [Evolution and physiology]. In R. Ekman & B. Arnetz (Eds.). *Stress: molekylerna, individen, organisationen och samhället* [Stress: The molecules, the individual, the organization and society] (pp 150-160). Stockholm: Liber.
- Gazzaniga, M. S., & Heatherton, T. F. (2003). *Psychological science: Mind, brain and behavior*. New York: Norton.
- Geels, A., & Wikström, O. (2006). *Den religiösa människan* [The religious human being]. Stockholm: Natur och Kultur.
- Ghatan, P. H. (2002). Stress och hjärnskaderehabilitering. [Stress and rehabilitation of brain injuries]. In R. Ekman & B. Arnetz (Eds.). *Stress: molekylerna, individen, organisationen och samhället* [Stress: The molecules, the individual, the organization and society] (pp 233-245). Stockholm: Liber.
- Goldberger, L. (1961). Reactions to perceptual isolation and Rorschach manifestations of the primary process. *Journal of Projective Techniques*, 25, 287-302.
- Gracely, R. H. (2006). Studies of pain in human subjects. In S. B. McMahon & M. Koltzenburg (Eds) Wall and Melzack's *Textbook of Pain*. (p. 275). Elsevier
- Grattan, D. R., Pi, X. J., Andrews, Z. B., Augustine, R. A., Kokay, I. C., Summer, M. R., Todd, B., & Bunn, S. J., (2001). Prolactin receptors in the brain during pregnancy and lactation implications for behavior. *Hormones and Behavior* 2, 115-24.
- Gustafsson, M. (2002). *Utbildning om långvarig smärta*. Omvårdnad som akademiskt ämne i forskning, utbildning och patientnära verksamhet [Education on chronic pain]. Svensk sjuksköterskeförening. Bromma Tryck AB, Sverige.
- Gustafsson, M. (1999). *Chronic pain experiences: studies of perception, evaluation and responses to pain in patients with rheumatoid arthritis and musculoskeletal pain*. Göteborg, Sweden: Department of Rehabilitation Medicine, Institute of Community Medicine, Göteborg University (dissertation).

- Herrmann, C. (1997). International experiences with the Hospital Anxiety and Depression scale: A review of validation data and clinical results. *Journal of Psychosomatic Research*, 42, 1741.
- Hess, W. R. (1957). *The functional organization of the diencephalon*. New York: Grune & Stratton.
- Huebner, E. S., & Dew, T. (1995). Preliminary validation of the positive and negative affect schedule with adolescent. *Journal of Psycho-educational assessment*, 13, 286-293.
- Hwang, P., Lundberg, I., Rönnerberg, J., & Smedler A. C. (2005). *Vår tids Psykologi* [Psychology in our time]. Stockholm. Natur & Kultur.
- Jansen, A. S. P., Nguyen, X. V., Karpitskiy, V., Mettenleiter, T. C., & Loewy, A. D. (1995). Central command neurons of the sympathetic nervous system: Basis of the fight-or-flight response. *Science*, 270, 644–646.
- Johannisson, K. (2002). När otillräckligheten byter namn. Ett idéhistoriskt perspektiv på den nya ohälsa [When the inadequacy changes its name. A perspective from the history of ideas on the new ill-health]. In R. Ekman & B. Arnetz (Eds.). *Stress: molekylerna, individen, organisationen och sambället* [Stress: The molecules, the individual, the organization and society] (pp 264-271). Stockholm: Liber.
- Jones, B. M. (2001). Changes in cytokine production in healthy subjects practicing Guolin Quigong: A pilot study. *Complementary Alternative Medicine* 1, 8.
- Josefsson, P., Kardadaghi, T., Klinge, A., Louca, S., Pourjanaki, G., & Svärd, M (2003). *Are there any differences between men and women in relation to pain and sensory thresholds?* Huddinge, Sweden: Institute of Odontology, Karolinska institutet.
- Julius, S., & Cottier. C. (1983). Behavior and hypertension. In T. Dembroski, T. Schmidt (Eds.). *Behavioral Bases of Coronary Heart Disease* (pp. 286-293). Basel, Switzerland: Karger.
- Kandel, E. R., Schwartz, J. H., & Jessell, T. M. (1991). *Principles of neural science*. Third edition. New York: Elsevier Science Publishing Co., Inc.

- Karlsson, G. (1995). *Psychological qualitative research from a phenomenological perspective*. Stockholm: Almqvist & Wiksell International.
- Keltikangas-Järvinen, L. (2000). Insulin resistance. In: G. Fink (Ed.). *Encyclopedia of stress*, 2, 582-586. London: Academic press.
- Kercher, K. (1992). Assessing, subjective well-being in the old-old: the PANAS as a measure of orthogonal dimensions of positive and negative affect. *Research on Aging*, 14, 131-168.
- Kiive, E., Maaroos, J., Shlik, J., Toru, I., & Harro, J. (2004). Growth hormone, cortisol and prolactin response in depressed patients. *Progress in Neuropsychopharmacology & Biological Psychiatry* 6, 1007-1013.
- Kjellberg, A., & Bohlin, B. (1974). Self-reported arousal: Further development of a multi-factorial inventory. *Scandinavian Journal of Psychology*, 15, 285-292.
- Kjellberg, A., & Iwanowski, S. (1989). *Stress/energi formuläret: Utveckling av en metod för skattning av sinnesstämning i arbetet* [The Stress/arousal questionnaire: Development of a method for assessment of mood at work]. Solna, Sweden: Arbetsmiljöinstitutet.
- Kjellgren, A. (2003). *The experience of flotation-REST (Restricted Environmental Stimulation Technique): Consciousness, Creativity, Subjective Stress and Pain*. Göteborg, Sweden: Doctorial dissertation, Göteborgs Universitet.
- Kjellgren, A., Sundeqvist, U., Norlander, T., & Archer, T. (2001). Effects of flotation-REST on muscle tension pain. *Pain Research and Management*, 6, 181-189.
- Kjellgren, A., Sundeqvist, U., Sundholm, U., Norlander, T., & Archer, T. (2004). Altered consciousness in flotation-REST and chamber-REST: Experience of experimental pain and subjective stress. *Social Behavior and Personality*, 32, 103 – 115.
- Lagerroth, E. (2006). *I hjärnan finns människan*. Hämtad den 6 september, 2006, via <http://home.swipnet.se/erland-lagerroth/matti.html>.

- Lawn, B., Verrier, R., & Rabinowitz, S. (1987). Neural and psychological mechanisms and the problem of sudden cardiac death. *American Journal of Cardiology*, 39, 890-902.
- Levi, L. (2002). Stress - en översikt. Internationella och folkhälsoperspektiv [Stress – a review. International and public health perspectives]. In R. Ekman & B. Arnetz (Eds.). *Stress: molekylerna, individen, organisationen och samhället* [Stress: The molecules, the individual, the organization and society] (pp 44-61). Stockholm: Liber.
- Lindholm, C. (1996). Smärta vid bensår och trycksår [Pain, wounds and decubitus]. *Vård*, 2, 97-103.
- Linton, S. J. (1982). Applied relaxation as a method of coping with chronic pain: a therapist's guide. *Scandinavian Journal of Behavior Therapy*, 11, 161-174.
- Linton, S. J. (2005). *Att förstå patienter med smärta* [Understanding patients with pain]. Stockholm: Studentlitteratur.
- Lundberg, U. (2002). Samspelet individ, samhälle, livsstil, och biologi [Interactions between individuals, society, way of life and biology]. In R. Ekman & B. Arnetz (Eds.). *Stress: molekylerna, individen, organisationen och samhället* [Stress: The molecules, the individual, the organization and society] (pp 275-288). Stockholm: Liber.
- Lundberg, U., & Wentz, G. (2004). *Stressad hjärna, stressad kropp: Om sambandet mellan psykisk stress och kroppslig ohälsa* [Connections between psychological stress and body ill health]. Stockholm: Wahlström & Widstrand.
- Lutgendorf, S., Logan, H., Kirchner, H. L., Rothrock, N., Svengalis, S., Iverson, K., & Lubaroff, D. (2000). Effects of relaxation and stress on the capsaicin-induced local inflammatory response. *Psychosomatic Medicine*, 62, 524-534.
- MacLean, P. D. (1973). *A Triune Concept of the Brain and Behavior*. Toronto: University Toronto Press.

- Marin, R., Cyhan, T., & Miklos, W. (2006). Sleep Disturbance in Patients With Chronic Low Back Pain. *American Journal of Physical Medicine & Rehabilitation*, 85, 430-435.
- Maslach, C., Schaufeli, W. B., & Leiter, M. P. (2001). Job burnout. *Annual Review Psychology*, 52, 397-422.
- Maslach, C. (1982). *Burnout - the cost of caring*. Englewood Cliffs, NJ: Prentice-Hall.
- Maslach, C. (1998). A multidimensional theory of burnout. In C. L. Cooper (Ed.). *Theories of Organizational Stress* (pp. 68-85). Oxford: Oxford University Press.
- McGrath, P. A. (1994). Psychological aspects of pain perception. *Archives of Oral Biological*, 39, 55-62.
- Melzack, R., & Wall, P. (1965). Pain Mechanisms: A new theory. *Science*, 150 171-179.
- Melzack, R., & Casey K. L. (1968). Sensory motivational and central control determinants of pain: A new conceptual model. In D. Kenshalo (Ed.). *The Skin Senses* (pp. 423-443). Springfield: Thomas.
- Melzack, R., & Wall, P. (1970). Psychophysiology of pain. *International Anesthesiology Clinics*, 8, 3-34.
- Melzack, R., & Wall, P. (1982). *The Challenge of pain*. New York: Basic Books.
- Melzack, R. (1999). Pain and stress: a new perspective. In R. J. Gatchel, & D. C. Turk (Eds.). *Psychosocial factors in pain* (pp. 89-106). New York: Guilford Press.
- Melzack, R. (1999). Pain – an overview. *Acta Anaesthesiologica Scandinavica*, 43, 880-884.
- Melzack, R. (1999). From the gate to the neuromatrix. *Pain*, 6, 121-126.
- Melzack, R. (2001). Pain and the neuromatrix in the brain. *Journal of Dental Education*, 65, 12.

- Melzack, R. (2005). Evolution of the neuromatrix theory of pain. *Pain Practice*, 5, 85-94.
- Mobily, P. R., Herr, K. A., Clark, K. M., & Wallace, R. B. (1994). An Epidemiologic analysis of pain in the elderly. *Journal of Aging and Health*, 6, 139-154.
- Munro, B. H., Creamer, A. M., Haggerty, M. R., & Cooper, F. S., (1988). Effect of relaxation therapy on post-myocardial infarction patients' rehabilitation. *Nursing Research*, 37, 231-235.
- Neisser, U. (1967). *Cognitive Psychology*. New York: Appleton Century Crofts.
- Niklasson, M. (2002). *Childhood playing is one of precursor for sustained higher cognitive skills and for emotional well being*. Mönsterås, Sweden: Vestibularis.
- Niklasson, M. (2005). *Gravitation and the vestibular system as a source for development and for sustained health*. Mönsterås, Sweden: Vestibularis.
- Nisell, R., & Lundeberg, T. (1993). *Smärta och inflammation*. Södertälje, Sweden: Syntex Nordica.
- Norlander, T. (1997). *Alcohol and the Creative Process. Frameworks of influence by alcohol upon creative performance*. Örebro, Sweden: Tryckverkstan.
- Norlander, T. (1999). Inebriation and inspiration? A review of the research on alcohol and creativity. *Journal of Creative Behavior*, 33, 7-29.
- Norlander, T., Bergman, H., & Archer, T. (1998). Effects of Flotation REST on creative problem solving and originality. *Journal of Environmental Psychology*, 18, 399-408.
- Norlander, T., Bergman, H., & Archer, T. (1999). Primary process in competitive archery performance: Effects of flotation REST. *Journal of Applied Sport Psychology*, 11, 194-209.
- Norlander, T., Bergman, H., & Archer, T. (2002). Relative constancy of personality characteristics and efficacy of a 12-month training program in facilitating coping strategies. *Social Behavior and Personality*, 30, 773-784.

- Norlander, T., Bood, S. Å., & Archer, T. (2002). Performance during stress: Affective personality, age, and regularity of physical exercise. *Social Behavior and Personality, 30*, 495-508.
- Norlander, T., Kjellgren, A., & Archer, T. (2001). The experience of flotation-REST as a function of setting and previous experience of altered state of consciousness. *Imagination, Cognition and Personality, 20*, 161-178.
- Norlander, T., Kjellgren, A., & Archer, T. (2003). Effects of flotation- versus chamber-restricted environmental stimulation technique (REST) on creativity and realism under stress and non-stress conditions. *Imagination, Cognition and Personality, 22*, 341-357.
- Norlander, T., Sandholm, C., & Anfelt, O. (1998). The physioacoustic method and the creative process. *Perceptual and Motor Skills, 86*, 1091-1096.
- Norton, P. J., Asmundson, G. G. J., Norton, G. R., & Craig K. D. (1999). Growing pain: 10-years research in the study of chronic pain and headache. *Pain 79*, 59-65.
- Nowlis, V., & Green, B. E. (1965). Research with the mood adjective checklist. In S.S., Tomkins & C. E., Izard (Eds.). *Affect, cognition and personality* (pp 352-389). New York: Springer.
- Noy, P. (1969). A revision of the psychoanalytic theory of the primary process. *International Journal of Psychoanalysis, 50*, 155-178.
- Roberts, S., & Barnes, D. (1990). The brain drain in stress. *The Journal of NIH Research, 2*, 70-71.
- Rööst, M., & Nilsson, P. (2002). Sömnbesvär - ett folkhälsoproblem [Sleep problems is a public health problem]. *Läkartidningen, 99*, 154-157.
- Sandlund, E. S., Linnarud, M., & Norlander, T. (2001). Effects of stress versus flotation-REST relaxation on creativity and literacy skills in advanced English as a Second Language (ESL) composition. RASK. *International Journal of Language & Communication, 15*, 95-113.
- Sandlund, E. S., & Norlander, T. (2000). The effects of Thai Chi Chuan relaxation and exercise on stress responses and well-being: An overview of research. *International Journal of Stress Management, 7*, 139-149.

- Scheier, M. F., & Carver, C. S. (1985). Optimism, Coping and Health: assessment and Implications of Generalized Outcome Expectancies. *Health Psychology, 4*, 219-247.
- Scheinin, M., Chang, W. H., Jimerson, D. C., & Linnoila, M. (1983). Measurement of 3-methoxy-4-hydroxyphenylglycol in human plasma with high performance liquid chromatography using electrochemical detection. *Analytical Biochemistry, 132*, 165-170.
- Schulz, P., & Kaspar, C-H. (1994). Neuroendocrine and psychological effects of restricted environmental stimulation technique in a floatation tank. *Biological Psychology, 37*, 161 -175.
- Seibel, M., & Taymor, M. (1985). Emotional aspects of infertility. *Fertility and Sterility, 37*, 137.
- Selye, H. (1974). *Stress without Distress*. Philadelphia: Lippincott.
- Setterlind, S. (1990). *Från hypnos och suggestion till avslappning och meditation*. En metod och forskningsöversikt. [From hypnosis and suggestion to relaxation and meditation]. Örebro, Sweden: Welins.
- Sjukvårdsrådgivningen, (2006). Stress. Hämtad 6 september, 2006, från: <http://www.sjukvardsradgivningen.se/>
- Sjöström, B. (2002). *Forskning kring långvarig smärta. Omvårdnad som akademiskt ämne i forskning, utbildning och patientnära verksamhet* [Research on chronic pain]. Svensk sjuksköterskeförening. Stockholm: Bromma Tryck AB.
- Skevington, S. M. (1995). *Psychology and pain*. Chicester: Wiley.
- Smith, J. C. (1993). *Understanding stress and coping*. New York: Macmillian Publishing Company.
- Smith, M. T., Perlis, M. L., & Haythornthwaite, J. A. (2004). Suicidal ideation in outpatients with chronic musculoskeletal pain: An exploratory study of the role of sleep onset insomnia and pain intensity. *The Clinical Journal of Pain, 20*, 111-118.
- Snyder, C. R., & Lopez, S. J. (2002). (Eds.). *Handbook of positive psychology*. New York: Oxford University Press.

- Sterner-Victorin, E., Kowalski, J., & Lundeberg, T. (2002). A new highly reliable instrument for assessment of pre- and postoperative gynecological pain. *Anesthesia & Analgesia*, 95, 151-157.
- Stenstrom, C. H., Arge, B., & Sundbom, A. (1996). Dynamic training versus relaxation training as home experience for patients with inflammatory rheumatic diseases. A randomized control study. *Scandinavian Journal of Rheumatology*, 23, 28-33.
- Sohlman, B. (2000). *Möjligheterna finns. Om hjälp för barn med läs- och skrivsvårigheter och andra inlärningsproblem*. Täby, Sweden: Sama förlag AB.
- Sorensen, J., Bengtsson, A., Backman, E., Henriksson, K. G., & Bengtsson, M. (1995). Fibromyalgia: effects of intravenous morphine, lidocaine, and ketamine. *Scandinavian Journal of Rheumatology*, 24, 360-365.
- Sperry, R. (1973a). Lateral specialization in the surgically separated hemispheres. In F. Schmitt, & F. Worden (Eds.), *The Neurosciences: third study program*, 3, 5-19, MIT Press, Cambridge, Mass.
- Sperry, R. (1973b). Lateral specialization of cerebral function in the surgically separated hemisphere. In F. J. McGulgan, & R. A. Schoonover, (Eds.), *The psychophysiology of thinking*, 209-229. New York. Academic Press.
- Trout, K. K. (2004). The neuromatrix theory of pain: implications for selected nonpharmacologic methods of pain relief for labor. *Journal of Midwifery & Women's Health*, 6, 482-488.
- Turk, D., & Meichenbaum, D. (1984). A cognitive-behavioral approach to pain management. In P. Wall, & R. Melzack (Eds.). *Textbook of Pain* (pp.). Edinburgh, Scotland: Churchill - Livingstone.
- Turner, J.H. (2000). *On the origins of human emotions*. Stanford: Stanford University Press.
- Turner, J.W., & Fine, T.H. (1984). REST-assisted relaxation and chronic pain, Presented at the XXIII International Congress of Psychology, Acapulco, Mexico, 3 September 1984.

- Uvnäs Moberg, K. (2002). Kroppens antistresssystem [The anti-stress system in the body]. In R. Ekman & B. Arnetz (Eds.). *Stress: molekylerna, individen, organisationen och samhället* [Stress: The molecules, the individual, the organization and society] (pp 90-99). Stockholm: Liber.
- Wall, P., & Melzack R. (2006). *Textbook of Pain*. London: Elsevier.
- Wallbaum, A. B., Rzewnicki, R., Steele, H., & Sudefeld, P. (1992). Progressive muscle relaxation and restricted environmental stimulation therapy for chronic tension headache: A pilot study. *International Journal of Psychosomatics*, 38, 33-39.
- Watson, D., Clark, L., & Tellegen, A. (1988). Development and validation of brief measures of positive and negative affect. The PANAS scale. *Journal of Personality and Social Psychology*, 54, 1063-1070.
- Werner, M., & Arnér, S. (2000). *Klinisk smärtfysiologi* [Clinical pain physiology]. Stockholm: Smärtgräns 2000. Janssen-Cilag AB.
- Werner, S., Bengtsson, B-Å., Petrus, B., Karlsson, A., Bolander, H., Bramnert, M., Valdemarsson, S., Bynke, O., Öhman, P., Olsson, T., Rasmuson, T., & Änggård, A. (1999). Prolaktin – hormon med många effekter [Prolactin – a hormone with many effects]. *Läkartidningen*, 96, 1171-1174.
- Wilson, K. G., Eriksson, M. Y., D'Eon, J. L., Mikail, S. F., & Emery, P. C. (2002). Major Depression and Insomnia in Chronic Pain. *Clinical Journal of Pain*, 18, 77-83.
- Währborg, P, & Friberg, P. (2002). Tidig utveckling av hjärt- och kärlsjukdom [Early development of coronal and heart deceases] In R. Ekman & B. Arnetz (Eds.). *Stress: molekylerna, individen, organisationen och samhället* [Stress: The molecules, the individual, the organisation and society] (pp 139-149). Stockholm: Liber.
- Yocum, D. E., Castro, W. L., Cornett, M. (2000). Exercise, education, and behavioral modification as alternative therapy for pain and stress in rheumatic disease. *Rheumatic Disease Clinical North America*, 26, 145-159.

Zigmond, A. S., & Snaith R. P. (1983). The hospital anxiety and depression scale. *Acta Psychiatrica Scandinavica*, 67, 361-370.

Bending and Mending the Neurosignature

The overarching purpose of the current thesis was to assess the long term effects of a treatment program involving flotation-REST for the experience of pain, from the point of view of variables connected with Melzack's neuromatrix theory, and to examine the extent of a potential attention-placebo effect in connection with flotation-REST.

The first study (Paper I) aimed to investigate long-term effects of flotation-REST four months after treatment. Seventy patients participated, diagnosed as having stress-related pain. Participants were randomly assigned to either a control group or a flotation-REST group and participated in a total of twelve flotation REST or control sessions. Results indicated that pain areas, stress, anxiety and depression decreased, while sleep quality, optimism, and prolactin increased. Positive effects generally maintained four months after treatment. The second (Paper II) examined the potential effects of attention-placebo. Thirty-two patients who were diagnosed as having stress-related muscular pain were treated for a period of six weeks. Half of the patients were also given attention for a period of 12 weeks, while the remainder received attention for 6 weeks. Participants in both groups exhibited lowered blood pressure, reduced pain, anxiety, depression, stress, and negative affectivity, as well as increased optimism, energy, and positive affectivity. The third (Paper III) investigated whether or not 33 flotation sessions were more effective for stress related ailments as compared to 12 sessions. Participants were 37 patients with stress related ailments. Analyzes for subjective pain and psychological variables typically indicated that 12 sessions were enough to get considerably improvements and no further improvements were noticed after 33 sessions. Finally, the fourth study (Paper IV) aimed to examine whether and how the combination of therapy and flotation tank could be used to treat patients with severe stress problems. Two women on long-term sick-leave participated in the study, which was carried out over a period of one year. Four overarching themes were generated: the therapeutic work model, transformation of feelings, self-insight and meaning. These together constituted a "therapeutic circle" which after a while transformed in to a "therapeutic spiral" of increased meaning and enhanced wellbeing.

It was therefore concluded that flotation tank therapy is an effective method for the treatment of stress-related pain.
